



SUBSTITUTION REQUEST

Project: Westmoore High School Entry Upgrades Substitution Request Number: 1
 From: Y.I. Specialties, Inc.
 To: OMNI Construction Co., LLC. Date: 5-14-26
1909 S. Eastern Ave Moore, OK 73160 A/E Project Number: _____
 Re: _____ Contract For: 101100 Chalkboards and Tackboards

Specification Title: 1011100 Chalkboards and Tackboard Description: Acceptable Manufacturers
 Section: 10 Page: 1 Article/Paragraph: 2.01/ A & B

Proposed Substitution: "PLATINUM VISUAL SOLUTIONS" BRAND
 Manufacturer: Platinum Visual Solutions Address: 1451 E. 6th St. Corona, CA Phone: 951-817-2200
 Trade Name: same Model No.: NTS Series
 Installer: _____ Address: _____ Phone: _____

History: New product 1-4 years old 5-10 years old More than 10 years old

Differences between proposed substitution and specified product: _____
none

Point-by-point comparative data attached — REQUIRED BY A/E

Reason for not providing specified item: COMPARABLE PRODUCT AT COMPETITIVE PRICE

Similar Installation:
 Project: Moore Public Schools Architect: Abla Griffin Partnership
 Address: _____ Owner: Moore Public Schools
 Date Installed: _____

Proposed substitution affects other parts of Work: No Yes; explain _____

Savings to Owner for accepting substitution: _____ (\$ _____).

Proposed substitution changes Contract Time: No Yes [Add] [Deduct] _____ days.

Supporting Data Attached: Drawings Product Data Samples Tests Reports _____

Boards: Narrow Hanger Bar Trim System [NTS]

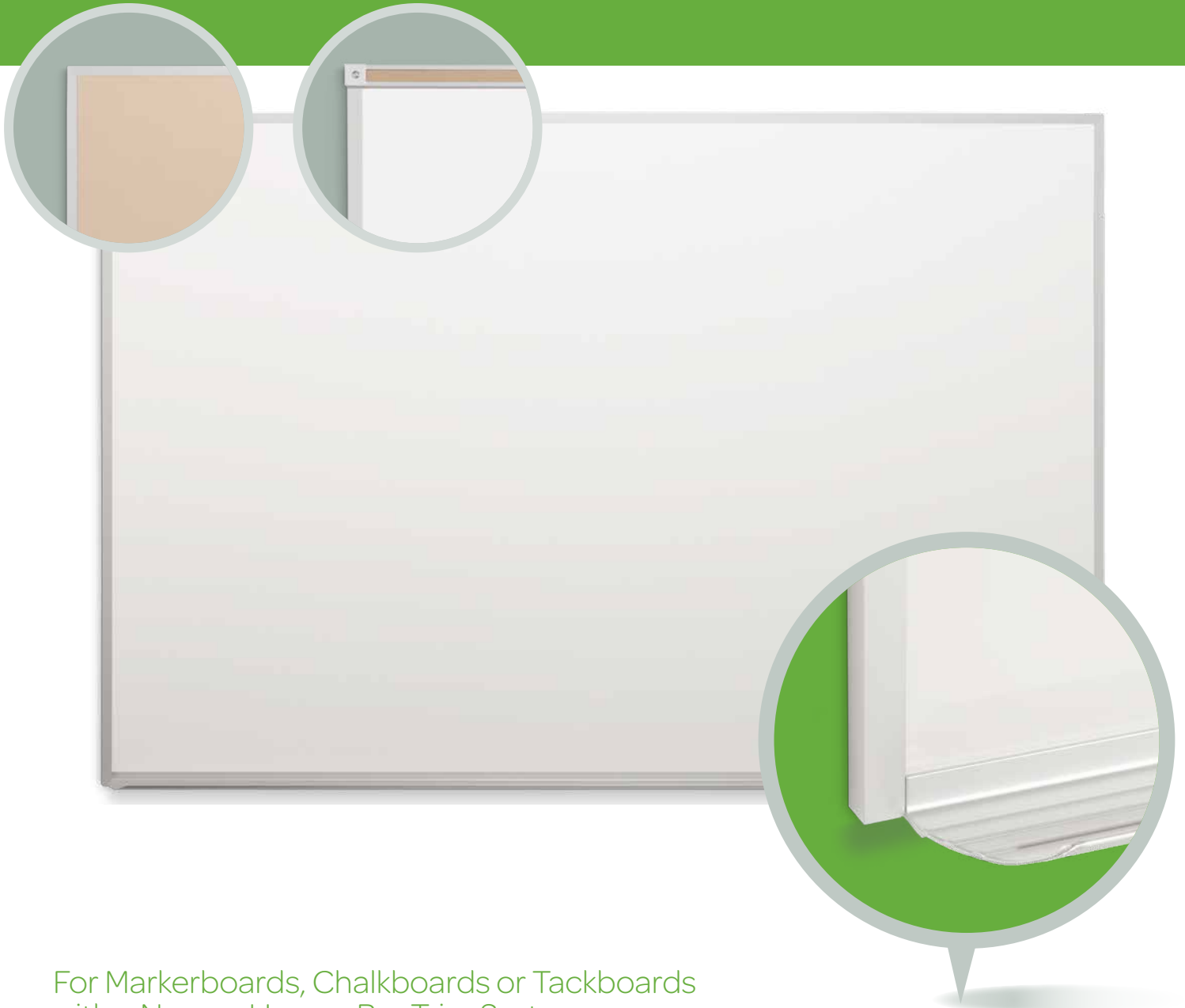

For Markerboards, Chalkboards or Tackboards with a Narrow Hanger Bar Trim System

- Porcelain-on-steel writing surfaces with a lifetime warranty.
- All extrusions are manufactured with high-quality aluminum alloy to exacting specifications.
- Heavy-duty aluminum extrusions come standard in clear satin anodized. Also available in optional dark bronze anodized or a variety of powder coated finishes.
- Concealed hanger bar for mounting.
- Safety first: radius blade tray ends equal no sharp edges.

Suggested Specifications

PART 1: *general*

1.1 SECTION INCLUDES

- A. Porcelain-on-Steel Markerboards.
- B. Porcelain-on-Steel Chalkboards.
- C. Colored Cork Tackboards.
- D. Visual Display Board Accessories.

1.2 RELATED SECTIONS

- A. Section 06100 – Wood or Steel Blocking.
- B. Section 09000 – Gypsum Wall Board.
- C. Section 09720 – Vinyl Wall Coverings.
- D. Section 09900 – Paints and Coatings.

1.3 REFERENCES

- A. ASTM B221 – Standard Specification for Aluminum and Aluminum-Alloy Extruded Bars, Rods, Wire, Shapes, and Tubes.
- B. ASTM E84 – Test Method for Surface Burning and Characteristics of Building Materials.
- C. ASTM C540 – Gloss Test for Porcelain Enamel Steel (Porcelain Enamel Institute PEI-501).

1.4 SUBMITTALS

- A. Submit products and samples under provisions of Section 01300.
- B. Product Data: Provide technical data for products specified. Include Material Safety Data Sheets, when applicable.
- C. Shop Drawings: Provide shop drawings for each type of visual display board specified including section details indicating trim, face, core and backing materials, dimensions, joint locations and special anchor details.
- D. Color Samples: Submit set of color chips displaying manufacturer's full range of colors and finishes.
- E. Product Samples: Submit samples not less than twelve inches square and framed on two adjacent sides, to illustrate materials, finish, color, and configuration of each type of visual display board required.
- F. Care and Maintenance Data: Provide data on cleaning requirements, stain removal, and recommended maintenance precautions.

1.5 DELIVERY, STORAGE AND HANDLING

- A. Comply with manufacturer's instructions for handling and storage of Visual Display Boards.

1.6 PROJECT CONDITIONS

- A. Field measure prior to fabrication to ensure proper fit.
- B. General contractor to maintain proper climate before, during and after installation.

1.7 WARRANTY

- A. Submit manufacturer's "Life of Building" warranty, stating that under normal usage and maintenance, and when installed in accordance with manufacturer's instructions and recommendations, Porcelain-on-Steel Markerboards and Chalkboards are guaranteed for the life of the building.
- B. Warranty shall cover replacement of defective Porcelain-on-Steel Markerboards and Chalkboards due to discoloration, excessive fading of color, crazing, cracking or flaking. Warranty does not cover the cost of removal or reinstallation.

PART 2: *products*

2.1 MANUFACTURERS

- A. Provide visual display boards as manufactured by Platinum Visual Systems™, Corona, California. Tel.: (800)498-2990 Fax: (951)817-9900. Email: info@pvsusa.com. Website: www.pvsusa.com.
- B. Substitutions: See Section 01600 – Product Requirements.

2.2 MARKERBOARD AND CHALKBOARD MATERIALS

- A. Steel Face Sheets: Writing surface will be Writanium® 28 gauge steel face with porcelain enamel finish fused to the steel sheet using a continuous coil process.
 - 1. Markerboard and Chalkboard surface shall be fused at a temperature of 1450° and 1200°, respectively.
 - 2. The gloss of the writing surface will not increase more than three units when subjected to wearability tests specified in testing procedures for 30 hours.

[NTS SERIES]

- B. Core Material: 1/2" particleboard.
- C. Backing Material: .005" aluminum backing sheet.
- D. Metal Trim and Accessories: 6063 aluminum alloy with a T5 temper.
- E. Adhesive: As recommended by manufacturer for project conditions.

2.3 PORCELAIN-ON-STEEL MARKERBOARDS AND CHALKBOARDS

- A. Provide Markerboards and Chalkboards for project from manufacturer's NTS Series.
 - 1. Metal trim and accessories: NTS Series aluminum extrusions with clear satin anodized finish.
 - a. Chalktray CR315: Standard continuous solid chalktray with ribbed section and smoothly curved and polished ends.
 - b. Map Rail MR411: Standard 1" high continuous rail with colored cork insert as follows:
 - 1) End stops: One pair per Map Rail.
 - 2) Map hooks: One every 2' of Map Rail.
 - 3) Roller brackets: One pair per Map Rail.
 - 4) Flag holder: One per room.
 - c. Frame CH235: Standard channel frame with 3/4" face and integrated hanger bar system.
 - d. Hanger Bar HB235: Standard hanger bar for concealed mounting to wall.
 - 2. Size: As shown on drawings.
 - 3. Color: As selected from manufacturer's standard colors.

2.4 COLORED CORK TACKBOARD MATERIALS

- A. Face Sheet: Colored cork surface will be 1/4" resilient homogenous tackable linoleum surface consisting of linseed oil, granulated cork, rosin binders and dry pigments calendared onto natural burlap backing. Color shall extend through thickness of material and be self-healing.
- B. Core Material: 1/4" medium density fiberboard.
- C. Metal Trim: 6063 aluminum alloy with T5 temper.
- D. Adhesive: As recommended by manufacturer for project conditions.

2.5 COLORED VINYL CORK TACKBOARDS

- A. Provide Tackboards for project from manufacturer's NTS Series.
 - 1. Metal trim and accessories: NTS Series aluminum extrusions with clear satin anodized finish.
 - a. Frame CH235: Standard channel frame with 3/4" face and integrated hanger bar system.
 - b. Hanger Bar HB235: Standard hanger bar for concealed mounting to wall.
 - 2. Size: As shown on drawings.
 - 3. Color: As selected from manufacturer's standard colors.

2.6 FABRICATION

- A. Laminate facing sheet and backing sheet to core material under pressure, using manufacturer's recommended adhesive.
- B. Provide factory-assembled visual display boards, except where sizes demand partial field assembly.
- C. Assemble units in one piece without joints, wherever possible. Where required dimensions exceed maximum panel size available, provide two or more pieces of equal length, as indicated on approved shop drawings. Assemble to verify fit at factory, then disassemble for delivery and final assembly at project site.

PART 3: *execution*

3.1 EXAMINATION

- A. Verify that substrates are properly prepared to receive visual display boards. Do not begin installation until unsatisfactory conditions have been corrected.

3.2 INSTALLATION

- A. Comply with manufacturer's installation instructions.
- B. Where visual display boards must be partly assembled at project site, use factory-supplied H-bar to maintain proper alignment.
- C. Install visual display boards level and plumb, keeping perimeter trim aligned in accordance with manufacturer's recommendations.

3.3 ADJUSTING AND CLEANING

- A. Verify that all accessories are installed as required for each unit.
- B. Upon completion of installation, clean surfaces and trim in accordance with manufacturer's recommendations, leaving all materials ready for use.

NTS: Specifications

MARKERBOARD/CHALKBOARD

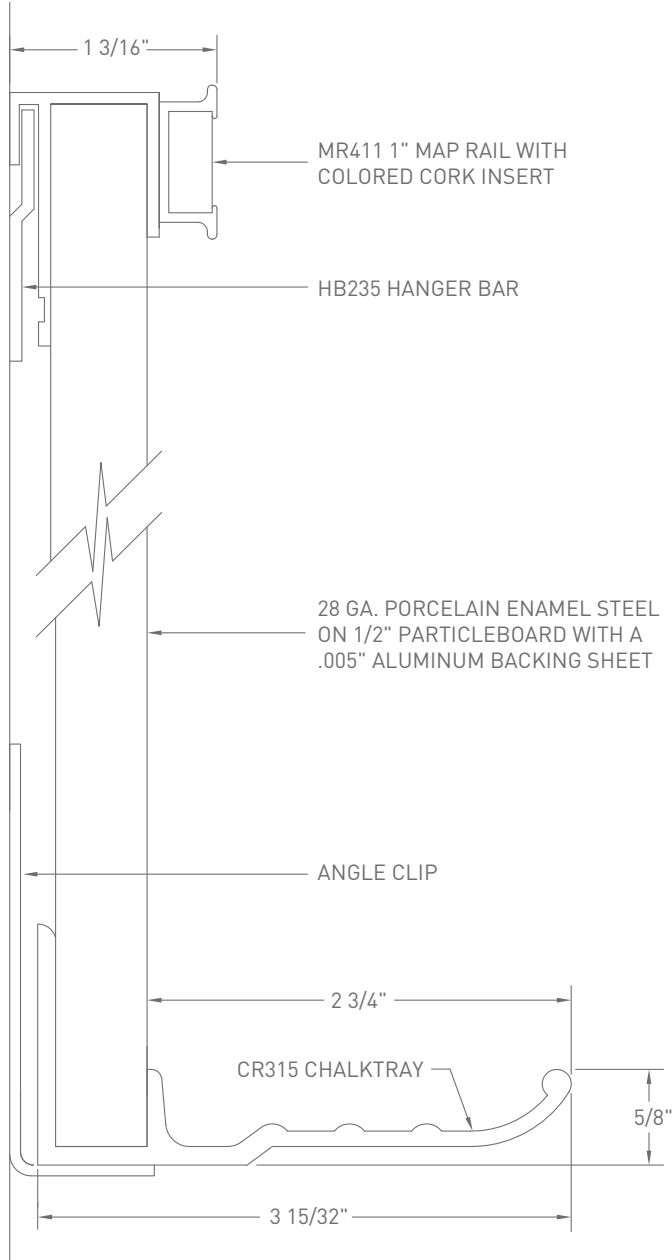

TACKBOARD

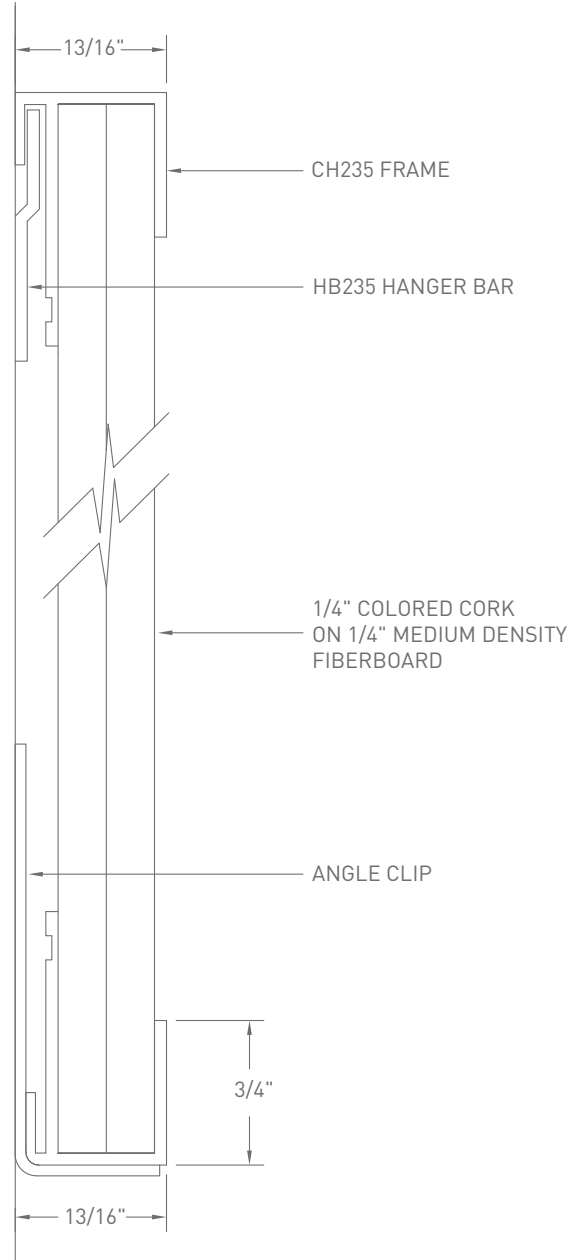

PLATINUM

LET'S CREATE TOGETHER.™

1451 E. Sixth Street, Corona, CA 92879
 800 498 2990 | 951 817 2200 | FAX 951 817 9900
www.pvsusa.com | info@pvsusa.com



PLATINUM

LET'S CREATE TOGETHER.™



GREAT IDEAS
START HERE





SIMPLY INSPIRING.

At Platinum Visual Systems, we work hard to make it easy for you to teach, create and innovate. So you can enjoy versatile, high quality products that simply inspire great ideas to break through. Want something unique? Call on our expert designers, engineers, and friendly customer service team – we think inside the board so you can go beyond it. From educators to architects, advertising to entertainment, small office to big business, we deliver whatever you need, on time, every time. It's that simple.

CONTENTS

BOARDS	PG	CUSTOMIZATION, ACCESSORIES AND ORDERING	PG
DTS Series	10-11	Dry Erase Markers	52
BTS Series	12-13	Magnetic Trays	52
WTS Series	14-15	Map Rail Accessories	53
NTS Series	16-17	Unframed Material	54
HTS Series	18-19	Roll Stock	55
WFS Series	20-21	Surface Colors	56-57
MTS Series	22	Trim System Colors	58
Graphic Boards with DTS Trim	23	Veneer & Finish Colors	58
Combination Boards	24-25	Terms & Conditions	59
Platinum Roll-Rite	26	Warranty	59
Roll-Rite Room Dividers	27		
Platinum Envirotack™ Tackboards	28		
EW Series	29		
Retrofit Boards	30		
Floor to Ceiling Markerboards	31		
SLIDING UNITS	PG		
Horizontal Sliding Units	32-36		
Vertical Sliding Units	37		
DISPLAY CASES	PG		
Bulletin and Directory Boards	38-40		
Trophy and Display Cases	41-42		
Executive Conference Units	43		
MAGNETIC GLASSBOARDS	PG		
GLASWRITE™ Series	44-46		
Accessories	46		
Contrasting Color Selections	47		
GLASWRITE MOBILEMATE™ Series	48-49		



LET'S CREATE TOGETHER.™

Platinum Visual Systems™ grew out of five decades of experience and our commitment to producing the absolute best in visual display products. The Platinum line promises precision engineering, the highest quality materials and exacting construction to ensure that every product meets our world-class standards. We even warranty our porcelain-on-steel surfaces for a lifetime of dependable use.

From our facility in Corona, California, we take pride in every aspect of delivering a top-quality visual display system. We manufacture our markerboards, chalkboards and tackboards under stringent quality controls, with a commitment to developing environmentally friendly visual products that qualify for today's stringent certification. Platinum uses superior heavy-duty 6063-T5 aluminum alloy exclusively to produce our aluminum extrusions. We create our tackable surfaces using only the finest quality materials. Our Writanium® writing surfaces are so beautifully designed and produced – incorporating the most advanced technology – we guarantee their performance for a lifetime.

Yet, no matter how well we make our products, they are not complete without top-notch service to back them up. You'll always enjoy friendly, courteous and helpful support every time we speak to you. If you have a question, we'll get it answered. If you have a complaint, we'll make it right. In everything we create and everything we do – it's your complete satisfaction that drives us to be the very best.

We make it easy. So you can be brilliant. Platinum Visual Systems continues to set the highest standard for quality, reliability and integrity in our products. Together with our unsurpassed service, that's an unbeatable combination. Call us and we'll prove it.





Because I offer a world of possibilities. So go ahead. Expand that new equation. Design that building. Teach. Brainstorm. Scribble. Dream. Invent. Discover. Save lives. Then, simply erase and start over again.

I'm proud of being blank.



We design our writing surfaces and tackable surfaces so you can choose the perfect medium for your message. Smart. Tough. Versatile. Long-lasting. They are simply the best communication tools you'll ever need. Our environmentally friendly markerboards, chalkboards and tackboards have earned SCS Certified Gold Indoor Advantage status and are proudly made in the USA. Versatile trim system options – including Box Tray, Drop-in Tray, Hanger Bar, Narrow Hanger Bar, Modular, Standard and Wide Profile – are available for all boards.



Platinum boards meet the gold level indoor air quality environmental standards of the Scientific Certification Systems

INDOOR ADVANTAGE GOLD BUILDING MATERIALS

WRITANIUM® MARKERBOARDS

Make your mark. Get on board with sharper color definition and higher contrast than any product you've used with vinyl dry erase or melamine surfaces. And say goodbye to ghosting, glare and light reflection. Our sleek, beautifully finished markerboard surfaces offer smooth writability to bring your visual presentations and displays vividly to life. The secret to our surface appeal: Writanium®.

- Porcelain-on-steel process creates a durable, nonporous surface with a high resistance to impacts, abrasions, scratching and fading.
- Engineered for superior color contrast with markers.
- Use any marker without damaging the surface.
- Wipe off dry erase ink easily with cloth or standard eraser.
- Remove other inks with appropriate cleaning agent or solvent-based cleaner.
- Magnetic aids hold and reposition easily.
- Permafuse™ custom imprints graphics like music staff lines, graphs, guidelines or logos.
- Flame resistant surface — 100% noncombustible.
- Lifetime warranty.



Platinum boards meet the gold level indoor air quality environmental standards of the Scientific Certification Systems

FROM ABC
TO PHD,
DISCOVER A
WORLD OF
POSSIBILITIES

on board.



WRITANIUM® CHALKBOARDS

Educate. Create. Erase. Repeat. Feel free to give our Writanium® Chalkboards a rough time. Use them again and again. For a lifetime, even. The controlled matte finish never gives up — and never allows glare or ghosting. Just clean, precise writing every time.

- Porcelain-on-steel process creates a durable, nonporous surface with a high resistance to impacts, abrasions, scratching and fading.
- Magnetic aids hold and reposition easily.
- Permafuse™ custom imprints graphics like music staff lines, graphs, guidelines or logos.
- Flame resistant surface — 100% noncombustible.
- Lifetime warranty.



COLORED CORK TACKBOARDS

Easily impressed. We construct our fine grain Colored Cork Tackboards in a variety of decor smart colors using 1/4" fine grain cork, burlap backed and laminated to 1/4" durable substrate. Environmentally friendly, fade free and soil resistant, our durable Colored Cork Tackboards self heal naturally and are dimensionally stable in all directions.

- Linoleum surface made from linseed oil, granulated cork, rosin binders and dry pigments for color throughout.
- Self-sanitizing quality inhibits contaminants.
- Warranty varies based upon tackboard material selection. Please contact your Platinum sales professional for details.



VINYL TACKBOARDS

Make a color statement. Versatile Vinyl Tackboards come in a variety of decor friendly colors in your choice of economical vinyl covered tackboard or vinyl covered cork tackboard. We'll laminate your favorite vinyl to two optional backings: a lightweight substrate or a layer of 1/8" cork on 3/8" lightweight substrate.

- Easy to clean, fade and soil resistant.
- Treated to resist the growth of odor and stain causing microbes.
- Warranty varies based upon tackboard material selection. Please contact your Platinum sales professional for details.



FABRIC TACKBOARDS

Pin-up Pretty. Tack in style with our versatile Fabric Tackboards in a variety of decor friendly colors. We'll laminate your choice of fabric to two optional backings: a lightweight substrate or a layer of 1/8" cork on 3/8" lightweight substrate.

- Fade and soil resistant.
- Treated to resist the growth of odor and stain causing microbes.
- Warranty varies based upon tackboard material selection. Please contact your Platinum sales professional for details.



NATURAL CORK TACKBOARDS

Go naturelle. Finely ground natural cork presents a smooth, resilient surface that remains pliable for years. Our classic corkboards feature 1/8" natural cork over a 3/8" lightweight substrate designed to be dimensionally stable in all directions. Beautiful, eco-friendly, and naturally-renewable corkboards promise a durable, self-healing surface.

- Resistant to soil and fading.
- Warranty varies based upon tackboard material selection. Please contact your Platinum sales professional for details.

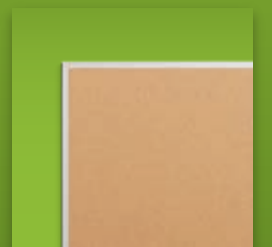

DROP-IN TRAY SYSTEM BOARDS (DTS)

- Porcelain-on-steel writing surfaces with a lifetime warranty.
- All extrusions are manufactured with high quality aluminum alloy to exacting specifications.
- Heavy-duty aluminum extrusions come standard in clear satin anodized. Also available in optional dark bronze anodized or a variety of powder coated finishes.
- Our drop-in trays for marker and chalk boards make for easy installation.
- Safety first: radius blade tray ends equal no sharp edges.
- All tackable surfaces ship fully framed and include hardware for installation.
- Custom sizes available.

MARKERBOARD (W/1" MAP RAIL)

MODEL	SIZE (HxW)
800130400	3'x 4'
800140400	4'x 4'
800140600	4'x 6'
800140800	4'x 8'
800141000	4'x 10'
800141200	4'x 12'
800141600	4'x 16'
800150800	5'x 8'
800151000	5'x 10'
800151200	5'x 12'
800151600	5'x 16'

MARKERBOARD (W/NO MAP RAIL)

MODEL	SIZE (HxW)
800030400	3'x 4'
800040400	4'x 4'
800040600	4'x 6'
800040800	4'x 8'
800041000	4'x 10'
800041200	4'x 12'
800041600	4'x 16'
800050800	5'x 8'
800051000	5'x 10'
800051200	5'x 12'
800051600	5'x 16'

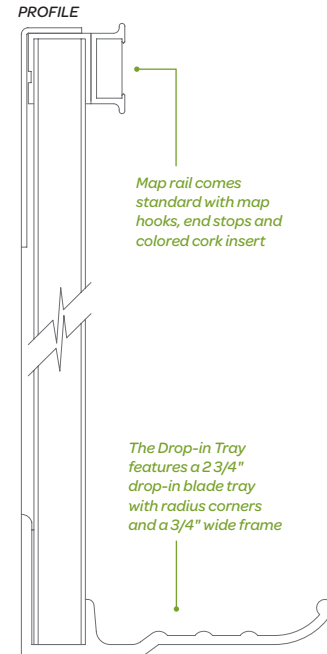

COLORED CORK TACKBOARDS (1/4" CORK ON 1/4" DURABLE SUBSTRATE)

MODEL	SIZE (HxW)
8006304XX	3'x 4'
8006404XX	4'x 4'
8006406XX	4'x 6'
8006408XX	4'x 8'
8006410XX	4'x 10'
8006412XX	4'x 12'

STANDARD VINYL TACKBOARDS (ON 1/2" LIGHTWEIGHT SUBSTRATE)

MODEL	SIZE (HxW)
8007304XX	3'x 4'
8007404XX	4'x 4'
8007406XX	4'x 6'
8007408XX	4'x 8'
8007410XX	4'x 10'
8007412XX	4'x 12'

PREMIUM VINYL TACKBOARDS (ON 1/8" CORK + 3/8" LIGHTWEIGHT SUBSTRATE)

MODEL	SIZE (HxW)
8008304XX	3'x 4'
8008404XX	4'x 4'
8008406XX	4'x 6'
8008408XX	4'x 8'
8008410XX	4'x 10'
8008412XX	4'x 12'

STANDARD FABRIC TACKBOARDS (ON 1/2" LIGHTWEIGHT SUBSTRATE)

MODEL	SIZE (HxW)
8010304XX	3'x 4'
8010404XX	4'x 4'
8010406XX	4'x 6'
8010408XX	4'x 8'
8010410XX	4'x 10'
8010412XX	4'x 12'

PREMIUM FABRIC TACKBOARDS (ON 1/8" CORK + 3/8" LIGHTWEIGHT SUBSTRATE)

MODEL	SIZE (HxW)
8011304XX	3'x 4'
8011404XX	4'x 4'
8011406XX	4'x 6'
8011408XX	4'x 8'
8011410XX	4'x 10'
8011412XX	4'x 12'

PREMIUM NATURAL CORK TACKBOARDS (1/8" NATURAL CORK ON 3/8" LIGHTWEIGHT SUBSTRATE)

MODEL	SIZE (HxW)
801330499	3'x 4'
801340499	4'x 4'
801340699	4'x 6'
801340899	4'x 8'
801341099	4'x 10'
801341299	4'x 12'



COLORED CORK TACKBOARDS



VINYL TACKBOARDS

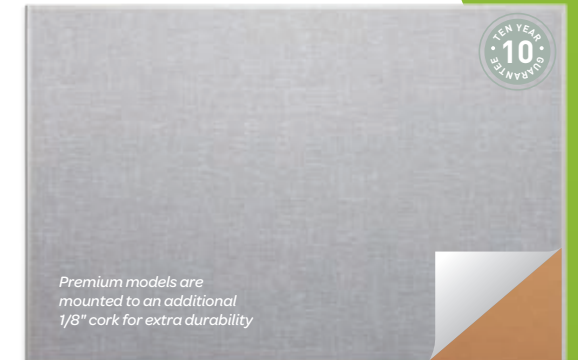

FABRIC TACKBOARDS

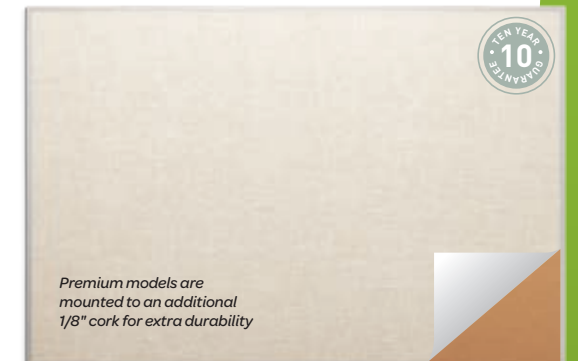

NATURAL CORK TACKBOARDS

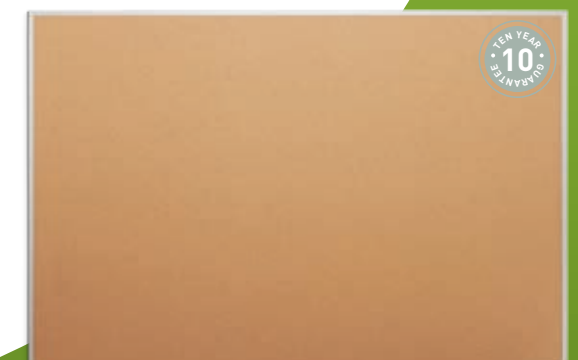

BOX TRAY TRIM SYSTEM (BTS)

- Porcelain-on-steel writing surfaces with a lifetime warranty.
- All extrusions are manufactured with high quality aluminum alloy to exacting specifications.
- Heavy-duty aluminum extrusions come standard in clear satin anodized. Also available in optional dark bronze anodized or a variety of powder coated finishes.
- Full length extruded aluminum box tray with cast aluminum end closures.
- All tackable surfaces ship fully framed and include hardware for installation.
- Custom sizes available.

MARKERBOARD (W/1" MAP RAIL)

MODEL	SIZE (HxW)
802130400	3'x 4'
802140400	4'x 4'
802140600	4'x 6'
802140800	4'x 8'
802141000	4'x 10'
802141200	4'x 12'
802141600	4'x 16'
802150800	5'x 8'
802151000	5'x10'
802151200	5'x 12'
802151600	5'x 16'

MARKERBOARD (W/NO MAP RAIL)

MODEL	SIZE (HxW)
802030400	3'x 4'
802040400	4'x 4'
802040600	4'x 6'
802040800	4'x 8'
802041000	4'x 10'
802041200	4'x 12'
802041600	4'x 16'
802050800	5'x 8'
802051000	5'x10'
802051200	5'x 12'
802051600	5'x 16'

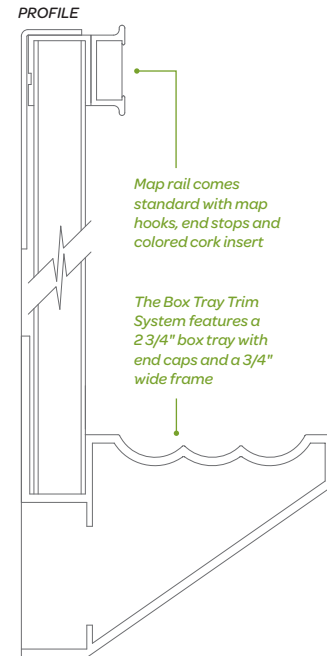

COLORED CORK TACKBOARDS (1/4" CORK ON 1/4" DURABLE SUBSTRATE)

MODEL	SIZE (HxW)
8026304XX	3'x 4'
8026404XX	4'x 4'
8026406XX	4'x 6'
8026408XX	4'x 8'
8026410XX	4'x 10'
8026412XX	4'x 12'

STANDARD VINYL TACKBOARDS (ON 1/2" LIGHTWEIGHT SUBSTRATE)

MODEL	SIZE (HxW)
8027304XX	3'x 4'
8027404XX	4'x 4'
8027406XX	4'x 6'
8027408XX	4'x 8'
8027410XX	4'x 10'
8027412XX	4'x 12'

PREMIUM VINYL TACKBOARDS (ON 1/8" CORK + 3/8" LIGHTWEIGHT SUBSTRATE)

MODEL	SIZE (HxW)
8028304XX	3'x 4'
8028404XX	4'x 4'
8028406XX	4'x 6'
8028408XX	4'x 8'
8028410XX	4'x 10'
8028412XX	4'x 12'

STANDARD FABRIC TACKBOARDS (ON 1/2" LIGHTWEIGHT SUBSTRATE)

MODEL	SIZE (HxW)
8030304XX	3'x 4'
8030404XX	4'x 4'
8030406XX	4'x 6'
8030408XX	4'x 8'
8030410XX	4'x 10'
8030412XX	4'x 12'

PREMIUM FABRIC TACKBOARDS (ON 1/8" CORK + 3/8" LIGHTWEIGHT SUBSTRATE)

MODEL	SIZE (HxW)
8031304XX	3'x 4'
8031404XX	4'x 4'
8031406XX	4'x 6'
8031408XX	4'x 8'
8031410XX	4'x 10'
8031412XX	4'x 12'

PREMIUM NATURAL CORK TACKBOARDS (1/8" NATURAL CORK ON 3/8" LIGHTWEIGHT SUBSTRATE)

MODEL	SIZE (HxW)
803330499	3'x 4'
803340499	4'x 4'
803340699	4'x 6'
803340899	4'x 8'
803341099	4'x 10'
803341299	4'x 12'



COLORED CORK TACKBOARDS



VINYL TACKBOARDS



FABRIC TACKBOARDS

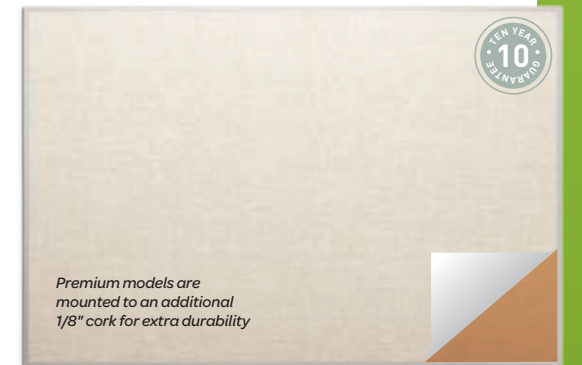

NATURAL CORK TACKBOARDS

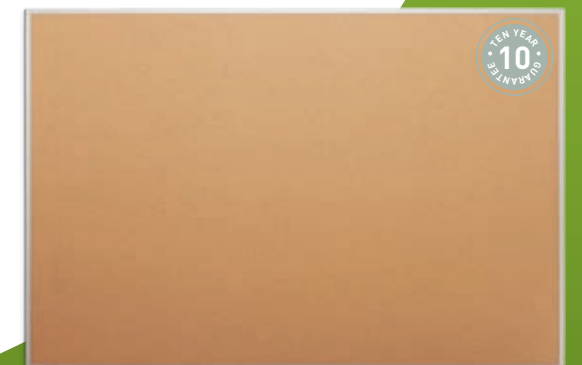

WIDE PROFILE TRIM SYSTEM (WTS)

- Porcelain-on-steel writing surfaces with a lifetime warranty.
- All extrusions are manufactured with high quality aluminum alloy to exacting specifications.
- Heavy-duty aluminum extrusions come standard in clear satin anodized. Also available in optional dark bronze anodized or a variety of powder coated finishes.
- Deluxe style trim for an institutional look.
- Enclosed box tray complements the wide profile frame.
- Custom sizes available.

MARKERBOARD (W/2" MAP RAIL)

MODEL	SIZE (HxW)
804230400	3'x 4'
804240400	4'x 4'
804240600	4'x 6'
804240800	4'x 8'
804241000	4'x 10'
804241200	4'x 12'
804241600	4'x 16'
804250800	5'x 8'
804251000	5'x10'
804251200	5'x 12'
804251600	5'x 16'

MARKERBOARD (W/NO MAP RAIL)

MODEL	SIZE (HxW)
804030400	3'x 4'
804040400	4'x 4'
804040600	4'x 6'
804040800	4'x 8'
804041000	4'x 10'
804041200	4'x 12'
804041600	4'x 16'
804050800	5'x 8'
804051000	5'x10'
804051200	5'x 12'
804051600	5'x 16'



COLORED CORK TACKBOARDS (1/4" CORK ON 1/4" DURABLE SUBSTRATE)

MODEL	SIZE (HxW)
8046304XX	3'x 4'
8046404XX	4'x 4'
8046406XX	4'x 6'
8046408XX	4'x 8'
8046410XX	4'x 10'
8046412XX	4'x 12'

STANDARD VINYL TACKBOARDS (ON 1/2" LIGHTWEIGHT SUBSTRATE)

MODEL	SIZE (HxW)
8047304XX	3'x 4'
8047404XX	4'x 4'
8047406XX	4'x 6'
8047408XX	4'x 8'
8047410XX	4'x 10'
8047412XX	4'x 12'

PREMIUM VINYL TACKBOARDS (ON 1/8" CORK + 3/8" LIGHTWEIGHT SUBSTRATE)

MODEL	SIZE (HxW)
8048304XX	3'x 4'
8048404XX	4'x 4'
8048406XX	4'x 6'
8048408XX	4'x 8'
8048410XX	4'x 10'
8048412XX	4'x 12'

STANDARD FABRIC TACKBOARDS (ON 1/2" LIGHTWEIGHT SUBSTRATE)

MODEL	SIZE (HxW)
8050304XX	3'x 4'
8050404XX	4'x 4'
8050406XX	4'x 6'
8050408XX	4'x 8'
8050410XX	4'x 10'
8050412XX	4'x 12'

PREMIUM FABRIC TACKBOARDS (ON 1/8" CORK + 3/8" LIGHTWEIGHT SUBSTRATE)

MODEL	SIZE (HxW)
8051304XX	3'x 4'
8051404XX	4'x 4'
8051406XX	4'x 6'
8051408XX	4'x 8'
8051410XX	4'x 10'
8051412XX	4'x 12'

PREMIUM NATURAL CORK TACKBOARDS (1/8" NATURAL CORK ON 3/8" LIGHTWEIGHT SUBSTRATE)

MODEL	SIZE (HxW)
805330499	3'x 4'
805340499	4'x 4'
805340699	4'x 6'
805340899	4'x 8'
805341099	4'x 10'
805341299	4'x 12'

COLORED CORK TACKBOARDS



VINYL TACKBOARDS



FABRIC TACKBOARDS

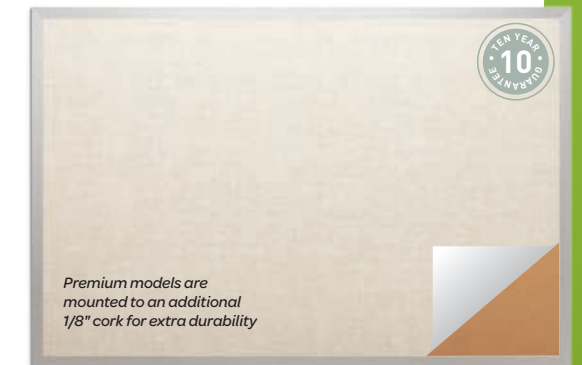

NATURAL CORK TACKBOARDS

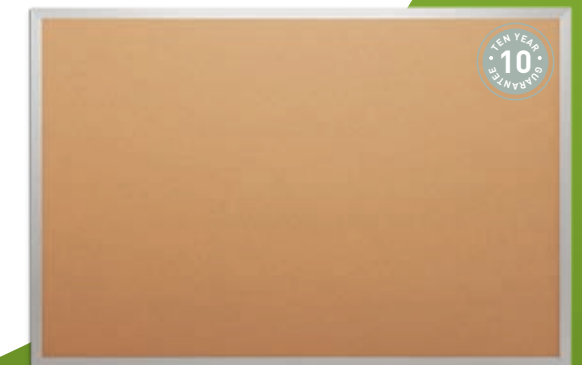

NARROW HANGER TRIM SYSTEM (NTS)

- Porcelain-on-steel writing surfaces with a lifetime warranty.
- All extrusions are manufactured with high quality aluminum alloy to exacting specifications.
- Heavy-duty aluminum extrusions come standard in clear satin anodized. Also available in optional dark bronze anodized or a variety of powder coated finishes.
- Concealed hanger bar for quick mounting.
- Custom sizes available.

MARKERBOARD (W/1" MAP RAIL)

MODEL	SIZE (HxW)
806130400	3'x 4'
806140400	4'x 4'
806140600	4'x 6'
806140800	4'x 8'
806141000	4'x 10'
806141200	4'x 12'
806141600	4'x 16'
806150800	5'x 8'
806151000	5'x10'
806151200	5'x 12'
806151600	5'x 16'

MARKERBOARD (W/NO MAP RAIL)

MODEL	SIZE (HxW)
806030400	3'x 4'
806040400	4'x 4'
806040600	4'x 6'
806040800	4'x 8'
806041000	4'x 10'
806041200	4'x 12'
806041600	4'x 16'
806050800	5'x 8'
806051000	5'x10'
806051200	5'x 12'
806051600	5'x 16'

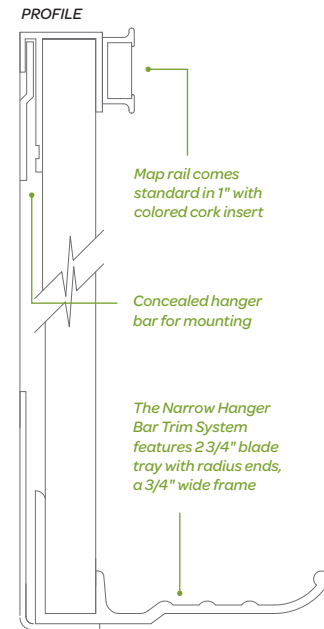

COLORED CORK TACKBOARDS (1/4" CORK ON 1/4" DURABLE SUBSTRATE)

MODEL	SIZE (HxW)
8066304XX	3'x 4'
8066404XX	4'x 4'
8066406XX	4'x 6'
8066408XX	4'x 8'
8066410XX	4'x 10'
8066412XX	4'x 12'

STANDARD VINYL TACKBOARDS (ON 1/2" LIGHTWEIGHT SUBSTRATE)

MODEL	SIZE (HxW)
8067304XX	3'x 4'
8067404XX	4'x 4'
8067406XX	4'x 6'
8067408XX	4'x 8'
8067410XX	4'x 10'
8067412XX	4'x 12'

PREMIUM VINYL TACKBOARDS (ON 1/8" CORK + 3/8" LIGHTWEIGHT SUBSTRATE)

MODEL	SIZE (HxW)
8068304XX	3'x 4'
8068404XX	4'x 4'
8068406XX	4'x 6'
8068408XX	4'x 8'
8068410XX	4'x 10'
8068412XX	4'x 12'

STANDARD FABRIC TACKBOARDS (ON 1/2" LIGHTWEIGHT SUBSTRATE)

MODEL	SIZE (HxW)
8070304XX	3'x 4'
8070404XX	4'x 4'
8070406XX	4'x 6'
8070408XX	4'x 8'
8070410XX	4'x 10'
8070412XX	4'x 12'

PREMIUM FABRIC TACKBOARDS (ON 1/8" CORK + 3/8" LIGHTWEIGHT SUBSTRATE)

MODEL	SIZE (HxW)
8071304XX	3'x 4'
8071404XX	4'x 4'
8071406XX	4'x 6'
8071408XX	4'x 8'
8071410XX	4'x 10'
8071412XX	4'x 12'

PREMIUM NATURAL CORK TACKBOARDS (1/8" NATURAL CORK ON 3/8" LIGHTWEIGHT SUBSTRATE)

MODEL	SIZE (HxW)
807330499	3'x 4'
807340499	4'x 4'
807340699	4'x 6'
807340899	4'x 8'
807341099	4'x 10'
807341299	4'x 12'

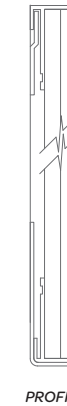

COLORED CORK TACKBOARDS



VINYL TACKBOARDS



FABRIC TACKBOARDS

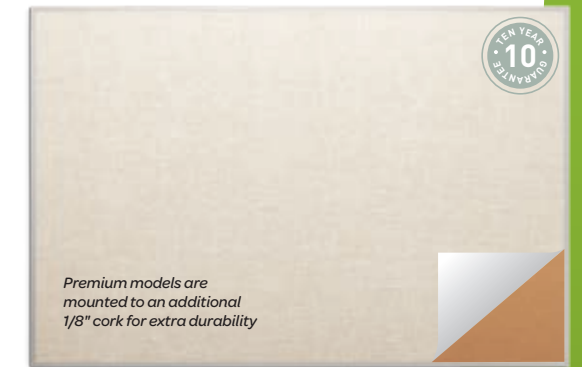

NATURAL CORK TACKBOARDS

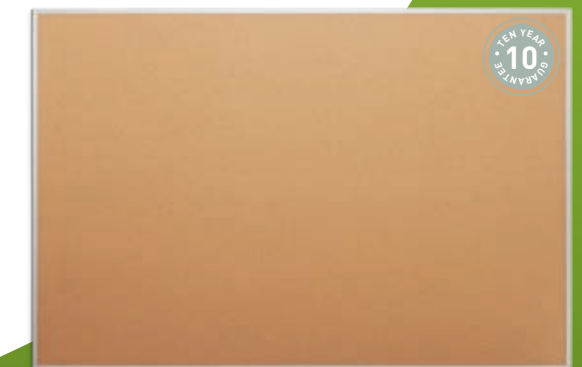

HANGER BAR TRIM SYSTEM (HTS)

- Porcelain-on-steel writing surfaces with a lifetime warranty.
- All extrusions are manufactured with high quality aluminum alloy to exacting specifications.
- Heavy-duty aluminum extrusions come standard in clear satin anodized. Also available in optional dark bronze anodized or a variety of powder coated finishes.
- Concealed hanger bar for quick mounting.
- Custom sizes available.

MARKERBOARD (W/1" MAP RAIL)

MODEL	SIZE (HxW)
808130400	3'x 4'
808140400	4'x 4'
808140600	4'x 6'
808140800	4'x 8'
808141000	4'x 10'
808141200	4'x 12'
808141600	4'x 16'
808150800	5'x 8'
808151000	5'x10'
808151200	5'x 12'
808151600	5'x 16'

MARKERBOARD (W/NO MAP RAIL)

MODEL	SIZE (HxW)
808030400	3'x 4'
808040400	4'x 4'
808040600	4'x 6'
808040800	4'x 8'
808041000	4'x 10'
808041200	4'x 12'
808041600	4'x 16'
808050800	5'x 8'
808051000	5'x10'
808051200	5'x 12'
808051600	5'x 16'

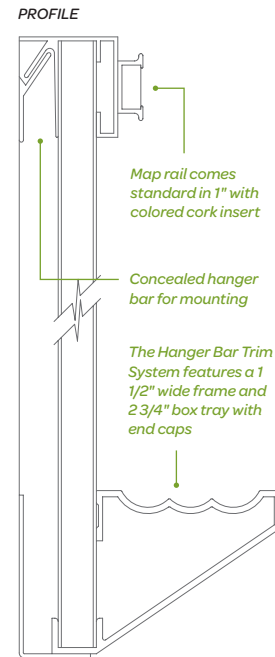

COLORED CORK TACKBOARDS (1/4" CORK ON 1/4" DURABLE SUBSTRATE)

MODEL	SIZE (HxW)
8086304XX	3'x 4'
8086404XX	4'x 4'
8086406XX	4'x 6'
8086408XX	4'x 8'
8086410XX	4'x 10'
8086412XX	4'x 12'

STANDARD VINYL TACKBOARDS (ON 1/2" LIGHTWEIGHT SUBSTRATE)

MODEL	SIZE (HxW)
8087304XX	3'x 4'
8087404XX	4'x 4'
8087406XX	4'x 6'
8087408XX	4'x 8'
8087410XX	4'x 10'
8087412XX	4'x 12'

PREMIUM VINYL TACKBOARDS (ON 1/8" CORK + 3/8" LIGHTWEIGHT SUBSTRATE)

MODEL	SIZE (HxW)
8088304XX	3'x 4'
8088404XX	4'x 4'
8088406XX	4'x 6'
8088408XX	4'x 8'
8088410XX	4'x 10'
8088412XX	4'x 12'

STANDARD FABRIC TACKBOARDS (ON 1/2" LIGHTWEIGHT SUBSTRATE)

MODEL	SIZE (HxW)
8090304XX	3'x 4'
8090404XX	4'x 4'
8090406XX	4'x 6'
8090408XX	4'x 8'
8090410XX	4'x 10'
8090412XX	4'x 12'

PREMIUM FABRIC TACKBOARDS (ON 1/8" CORK + 3/8" LIGHTWEIGHT SUBSTRATE)

MODEL	SIZE (HxW)
8091304XX	3'x 4'
8091404XX	4'x 4'
8091406XX	4'x 6'
8091408XX	4'x 8'
8091410XX	4'x 10'
8091412XX	4'x 12'

PREMIUM NATURAL CORK TACKBOARDS (1/8" NATURAL CORK ON 3/8" LIGHTWEIGHT SUBSTRATE)

MODEL	SIZE (HxW)
809330499	3'x 4'
809340499	4'x 4'
809340699	4'x 6'
809340899	4'x 8'
809341099	4'x 10'
809341299	4'x 12'



COLORED CORK TACKBOARDS



VINYL TACKBOARDS



FABRIC TACKBOARDS

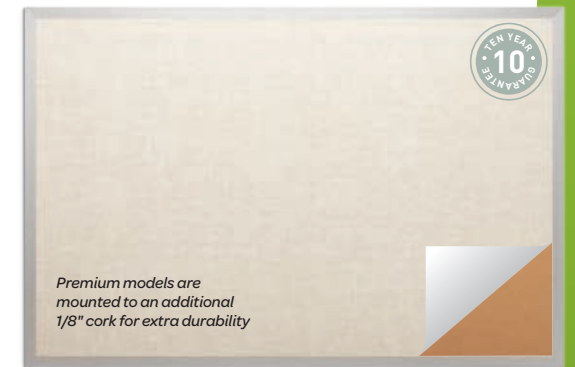

NATURAL CORK TACKBOARDS

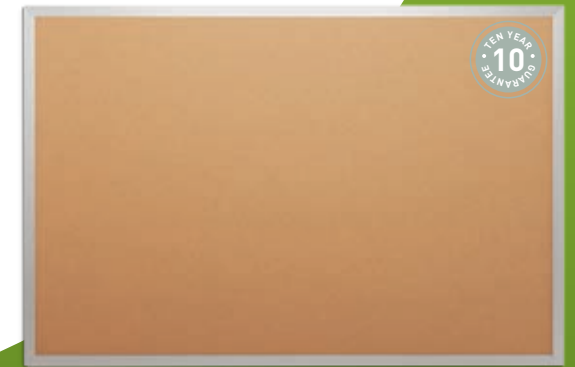

WOOD FRAME TRIM SERIES (WFS)

- Porcelain-on-steel writing surfaces with a lifetime warranty.
- Frames are solid oak hardwood with clear finish.
- Precision mitered corners.
- With or without tray.
- All tackable surfaces ship fully framed and include hardware for installation.

MARKERBOARD (W/TRAY)

MODEL	SIZE (HxW)
828130400	3'x 4'
828140400	4'x 4'
828140600	4'x 6'
828140800	4'x 8'
828141000	4'x 10'
828141200	4'x 12'

MARKERBOARD (W/NO TRAY)

MODEL	SIZE (HxW)
828030400	3'x 4'
828040400	4'x 4'
828040600	4'x 6'
828040800	4'x 8'
828041000	4'x 10'
828041200	4'x 12'

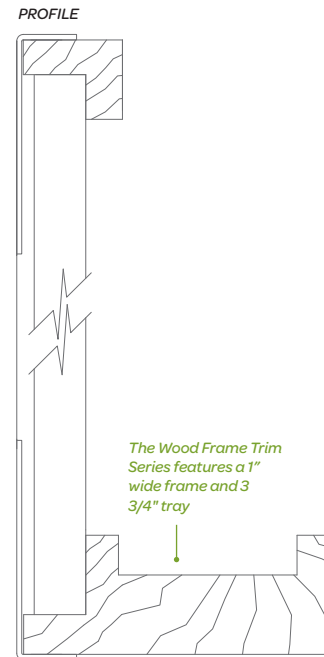

COLORED CORK TACKBOARDS (1/4" CORK ON 1/4" DURABLE SUBSTRATE)

MODEL	SIZE (HxW)
8286304XX	3'x 4'
8286404XX	4'x 4'
8286406XX	4'x 6'
8286408XX	4'x 8'
8286410XX	4'x 10'
8286412XX	4'x 12'

STANDARD VINYL TACKBOARDS (ON 1/2" LIGHTWEIGHT SUBSTRATE)

MODEL	SIZE (HxW)
8287304XX	3'x 4'
8287404XX	4'x 4'
8287406XX	4'x 6'
8287408XX	4'x 8'
8287410XX	4'x 10'
8287412XX	4'x 12'

STANDARD FABRIC TACKBOARDS (ON 1/2" LIGHTWEIGHT SUBSTRATE)

MODEL	SIZE (HxW)
8290304XX	3'x 4'
8290404XX	4'x 4'
8290406XX	4'x 6'
8290408XX	4'x 8'
8290410XX	4'x 10'
8290412XX	4'x 12'

PREMIUM NATURAL CORK TACKBOARDS (1/8" NATURAL CORK ON 3/8" LIGHTWEIGHT SUBSTRATE)

MODEL	SIZE (HxW)
829330499	3'x 4'
829340499	4'x 4'
829340699	4'x 6'
829340899	4'x 8'
829341099	4'x 10'
829341299	4'x 12'

PREMIUM VINYL TACKBOARDS (ON 1/8" CORK + 3/8" LIGHTWEIGHT SUBSTRATE)

MODEL	SIZE (HxW)
8288304XX	3'x 4'
8288404XX	4'x 4'
8288406XX	4'x 6'
8288408XX	4'x 8'
8288410XX	4'x 10'
8288412XX	4'x 12'

PREMIUM FABRIC TACKBOARDS (ON 1/8" CORK + 3/8" LIGHTWEIGHT SUBSTRATE)

MODEL	SIZE (HxW)
8291304XX	3'x 4'
8291404XX	4'x 4'
8291406XX	4'x 6'
8291408XX	4'x 8'
8291410XX	4'x 10'
8291412XX	4'x 12'

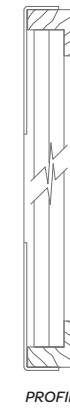

COLORED CORK TACKBOARDS



VINYL TACKBOARDS



FABRIC TACKBOARDS



NATURAL CORK TACKBOARDS



MODULAR TRIM SYSTEM (MTS)

- Porcelain-on-steel writing surfaces with a lifetime warranty.
- All extrusions are manufactured with high quality aluminum alloy to exacting specifications.
- Heavy-duty aluminum extrusions come standard in clear satin anodized. Also available in optional dark bronze anodized or a variety of powder coated finishes.
- Boards adjust in 2" increments.
- Mix and match writing and tackable surfaces.
- Boards lock in place for added safety.
- Support standards sold separately.

MARKERBOARD (W/1" MAP RAIL)

MODEL	SIZE (HxW)
810140400	4'x 4'
810140800	4'x 8'
810150400	5'x 4'
810150800	5'x 8'

MARKERBOARD (W/NO MAP RAIL)

MODEL	SIZE (HxW)
810040400	4'x 4'
810040800	4'x 8'
810050400	5'x 4'
810050800	5'x 8'

COLORED CORK TACKBOARDS (1/4" CORK ON 1/4" DURABLE SUBSTRATE)

MODEL	SIZE (HxW)
8106404XX	4'x 4'
8106408XX	4'x 8'

PREMIUM VINYL TACKBOARDS (ON 1/8" CORK + 3/8" LIGHTWEIGHT SUBSTRATE)

MODEL	SIZE (HxW)
8108404XX	4'x 4'
8108408XX	4'x 8'

PREMIUM FABRIC TACKBOARDS (ON 1/8" CORK + 3/8" LIGHTWEIGHT SUBSTRATE)

MODEL	SIZE (HxW)
8111404XX	4'x 4'
8111408XX	4'x 8'

SUPPORT STANDARDS

MODEL	SIZE (HxW)
854000100	72" single
854000200	72" double

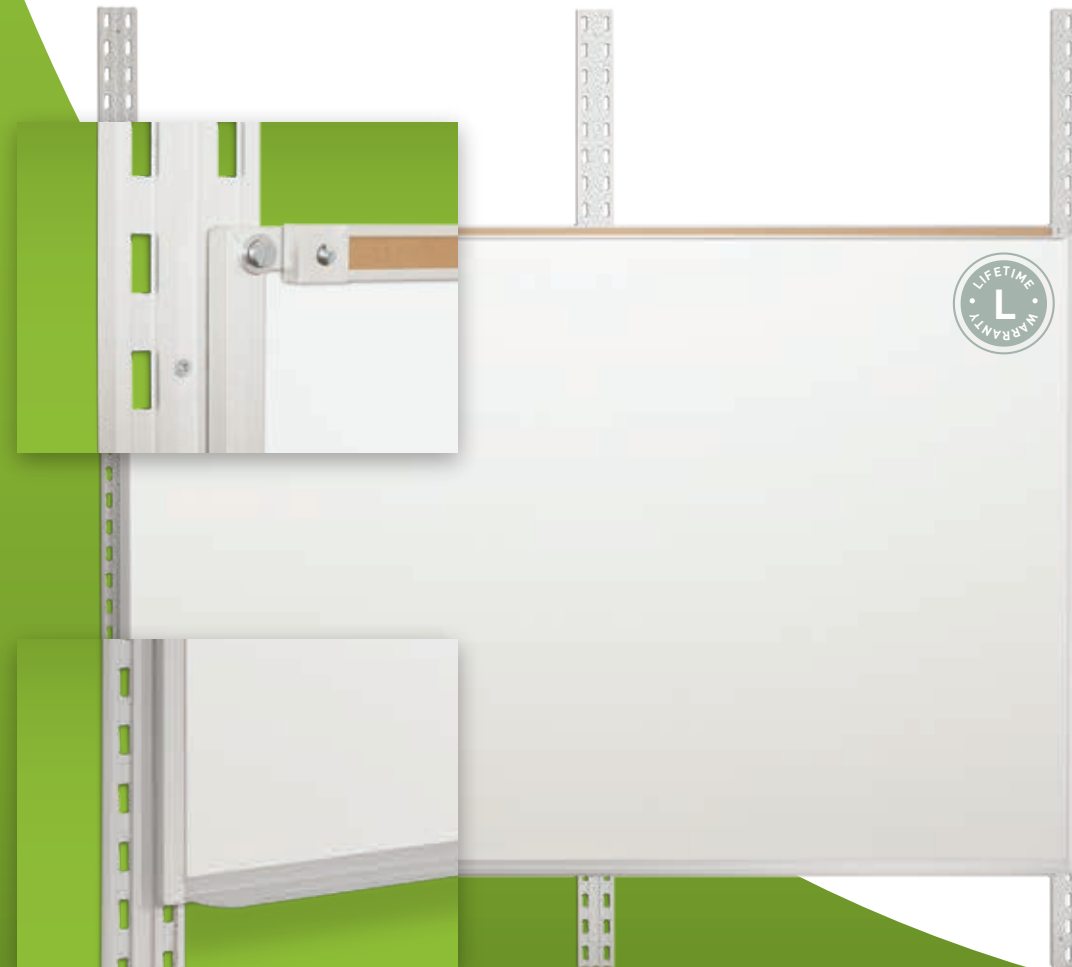
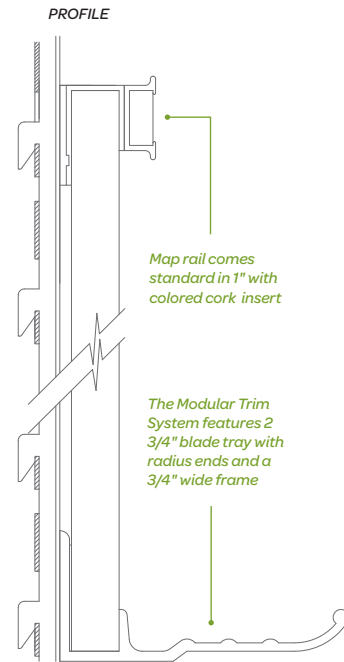

GRAPHIC BOARDS with DTS TRIM

A picture worth a thousand words. Graphic Boards take our markerboards and chalkboards to the next level, transforming them into specialized tools for your educational, business or creative needs. From simple penmanship lines to company logos, we imprint the graphic images you need into the board surface. You enjoy the same smooth writing and quick, easy erasure with no glare, reflection or ghosting.

- Permafuse™ process seamlessly embeds UV-resistant graphics into surface.
- Custom graphics include music staff lines, graphs, grids, lines, maps or logos.
- Durable, nonporous, scratch-resistant surface to protect against impacts, abrasions, scratching and fading.
- Magnetic aids hold and reposition easily.
- Only available in bright white finish.

 PLEASE CALL US AT 800 498 2990 FOR ALTERNATE TRIM AND GRAPHIC OPTIONS



MUSIC LINES

MODEL	SIZE (HxW)
832140600	4'x 6'
832140800	4'x 8'
832141000	4'x 10'



2" x 2" GRID PATTERN

MODEL	SIZE (HxW)
832340600	4'x 6'
832340800	4'x 8'
832341000	4'x 10'



PENMANSHIP LINES

MODEL	SIZE (HxW)
832240600	4'x 6'
832240800	4'x 8'
832241000	4'x 10'



CALENDAR (30 DAY)

MODEL	SIZE (HxW)
8330403631	4'x 3'



CALENDAR (2 MONTH PLANNER)

MODEL	SIZE (HxW)
8330304628	3'x 4' (Planner)



COMBINATION BOARDS

A winning combination. Take advantage of our versatile, multi-purpose Combination Boards when you need one board to do double or triple duty. Choose the surfaces that work best for your needs, from our sleek Writanium® chalkboards and markerboards to our durable tackboards. We'll configure your multitasking board in a variety of different modules to suit your needs.

- Porcelain-on-steel, magnetic writing surfaces.
- Heavy-duty aluminum extrusions in clear satin anodized.
- 10 year guarantee on all tackboard surfaces.
- Standard with 1" map rail.
- Convenient DTS Series accessory tray.
- Lifetime warranty on Writanium® surfaces.

TYPE A 1/2 MARKERBOARD ON THE RIGHT & 1/2 COLORED CORK, NATURAL CORK, VINYL OR FABRIC ON THE LEFT WITH DTS TRIM

MODEL	SIZE (HxW)	MODEL	SIZE (HxW)	MODEL	SIZE (HxW)	MODEL	SIZE (HxW)
8301404XX	4' x 4'	830240499	4' x 4'	8303404XX	4' x 4'	8304404XX	4' x 4'
8301406XX	4' x 6'	830240699	4' x 6'	8303406XX	4' x 6'	8304406XX	4' x 6'
8301408XX	4' x 8'	830240899	4' x 8'	8303408XX	4' x 8'	8304408XX	4' x 8'
8301410XX	4' x 10'	830241099	4' x 10'	8303410XX	4' x 10'	8304410XX	4' x 10'
8301412XX	4' x 12'	830241299	4' x 12'	8303412XX	4' x 12'	8304412XX	4' x 12'

8301 = COLORED CORK BULLETIN BOARD 8302 = NATURAL CORK BULLETIN BOARD 8303 = VINYL COVERED BULLETIN BOARD 8304 = FABRIC COVERED BULLETIN BOARD

TYPE B 1/2 MARKERBOARD ON THE LEFT & 1/2 COLORED CORK, NATURAL CORK, VINYL OR FABRIC ON THE RIGHT WITH DTS TRIM

MODEL	SIZE (HxW)	MODEL	SIZE (HxW)	MODEL	SIZE (HxW)	MODEL	SIZE (HxW)
8355404XX	4' x 4'	835640499	4' x 4'	8357404XX	4' x 4'	8358404XX	4' x 4'
8355406XX	4' x 6'	835640699	4' x 6'	8357406XX	4' x 6'	8358406XX	4' x 6'
8355408XX	4' x 8'	835640899	4' x 8'	8357408XX	4' x 8'	8358408XX	4' x 8'
8355410XX	4' x 10'	835641099	4' x 10'	8357410XX	4' x 10'	8358410XX	4' x 10'
8355412XX	4' x 12'	835641299	4' x 12'	8357412XX	4' x 12'	8358412XX	4' x 12'

8355 = COLORED CORK BULLETIN BOARD 8356 = NATURAL CORK BULLETIN BOARD 8357 = VINYL COVERED BULLETIN BOARD 8358 = FABRIC COVERED BULLETIN BOARD

TYPE C 2/3 MARKERBOARD ON THE LEFT & 1/3 COLORED CORK, NATURAL CORK, VINYL OR FABRIC ON THE RIGHT WITH DTS TRIM

MODEL	SIZE (HxW)	MODEL	SIZE (HxW)	MODEL	SIZE (HxW)	MODEL	SIZE (HxW)
8316404XX	4' x 4'	831740499	4' x 4'	8318404XX	4' x 4'	8319404XX	4' x 4'
8316406XX	4' x 6'	831740699	4' x 6'	8318406XX	4' x 6'	8319406XX	4' x 6'
8316408XX	4' x 8'	831740899	4' x 8'	8318408XX	4' x 8'	8319408XX	4' x 8'
8316410XX	4' x 10'	831741099	4' x 10'	8318410XX	4' x 10'	8319410XX	4' x 10'
8316412XX	4' x 12'	831741299	4' x 12'	8318412XX	4' x 12'	8319412XX	4' x 12'

8316 = COLORED CORK BULLETIN BOARD 8317 = NATURAL CORK BULLETIN BOARD 8318 = VINYL COVERED BULLETIN BOARD 8319 = FABRIC COVERED BULLETIN BOARD

TYPE D 2/3 MARKERBOARD ON THE RIGHT & 1/3 COLORED CORK, NATURAL CORK, VINYL OR FABRIC ON THE LEFT WITH DTS TRIM

MODEL	SIZE (HxW)	MODEL	SIZE (HxW)	MODEL	SIZE (HxW)	MODEL	SIZE (HxW)
8360404XX	4' x 4'	836140499	4' x 4'	8362404XX	4' x 4'	8363404XX	4' x 4'
8360406XX	4' x 6'	836140699	4' x 6'	8362406XX	4' x 6'	8363406XX	4' x 6'
8360408XX	4' x 8'	836140899	4' x 8'	8362408XX	4' x 8'	8363408XX	4' x 8'
8360410XX	4' x 10'	836141099	4' x 10'	8362410XX	4' x 10'	8363410XX	4' x 10'
8360412XX	4' x 12'	836141299	4' x 12'	8362412XX	4' x 12'	8363412XX	4' x 12'

8360 = COLORED CORK BULLETIN BOARD 8361 = NATURAL CORK BULLETIN BOARD 8362 = VINYL COVERED BULLETIN BOARD 8363 = FABRIC COVERED BULLETIN BOARD

TYPE E 1/4 COLORED CORK, NATURAL CORK, VINYL OR FABRIC, 1/2 MARKERBOARD, 1/4 COLORED CORK, NATURAL CORK, VINYL OR FABRIC WITH DTS TRIM

MODEL	SIZE (HxW)	MODEL	SIZE (HxW)	MODEL	SIZE (HxW)	MODEL	SIZE (HxW)
8311410XX	4' x 10'	831241099	4' x 10'	8313410XX	4' x 10'	8314410XX	4' x 10'
8311412XX	4' x 12'	831241299	4' x 12'	8313412XX	4' x 12'	8314412XX	4' x 12'
8311416XX	4' x 16'	831241699	4' x 16'	8313416XX	4' x 16'	8314416XX	4' x 16'

8311 = COLORED CORK BULLETIN BOARD 8312 = NATURAL CORK BULLETIN BOARD 8313 = VINYL COVERED BULLETIN BOARD 8314 = FABRIC COVERED BULLETIN BOARD

TYPE F 4'H MARKERBOARD WITH 1'H HEADER IN COLORED CORK, NATURAL CORK, VINYL OR FABRIC WITH DTS TRIM

MODEL	SIZE (HxW)	MODEL	SIZE (HxW)	MODEL	SIZE (HxW)	MODEL	SIZE (HxW)
8306506XX	5' x 6'	830750699	5' x 6'	8308506XX	5' x 6'	8309506XX	5' x 6'
8306508XX	5' x 8'	830750899	5' x 8'	8308508XX	5' x 8'	8309508XX	5' x 8'
8306510XX	5' x 10'	830751099	5' x 10'	8308510XX	5' x 10'	8309510XX	5' x 10'
8306512XX	5' x 12'	830751299	5' x 12'	8308512XX	5' x 12'	8309512XX	5' x 12'

8306 = COLORED CORK BULLETIN BOARD 8307 = NATURAL CORK BULLETIN BOARD 8308 = VINYL COVERED BULLETIN BOARD 8309 = FABRIC COVERED BULLETIN BOARD

TYPE G 4'H BOARD WITH 1'H HEADER IN COLORED CORK, NATURAL CORK, VINYL OR FABRIC WITH DTS TRIM

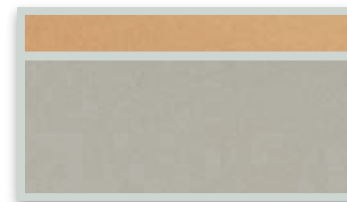

TYPE H 2/3 MARKERBOARD ON THE LEFT & 1/3 COLORED CORK, NATURAL CORK, VINYL OR FABRIC ON THE RIGHT WITH 1'H HEADER IN COLORED CORK, NATURAL CORK, VINYL OR FABRIC WITH DTS TRIM

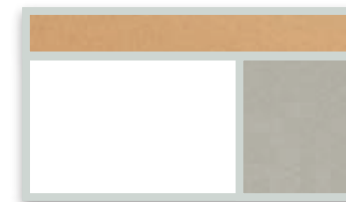

TYPE I 2/3 MARKERBOARD ON THE RIGHT & 1/3 COLORED CORK, NATURAL CORK, VINYL OR FABRIC ON THE LEFT WITH 1'H HEADER IN COLORED CORK, NATURAL CORK, VINYL OR FABRIC WITH DTS TRIM

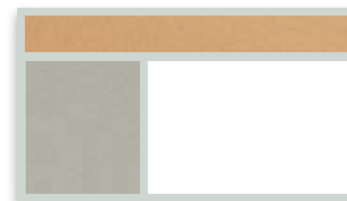

TYPE J 1/2 MARKERBOARD IN THE CENTER & 1/4 COLORED CORK, NATURAL CORK, VINYL OR FABRIC ON EACH SIDE WITH 1'H HEADER IN COLORED CORK, NATURAL CORK, VINYL OR FABRIC WITH DTS TRIM

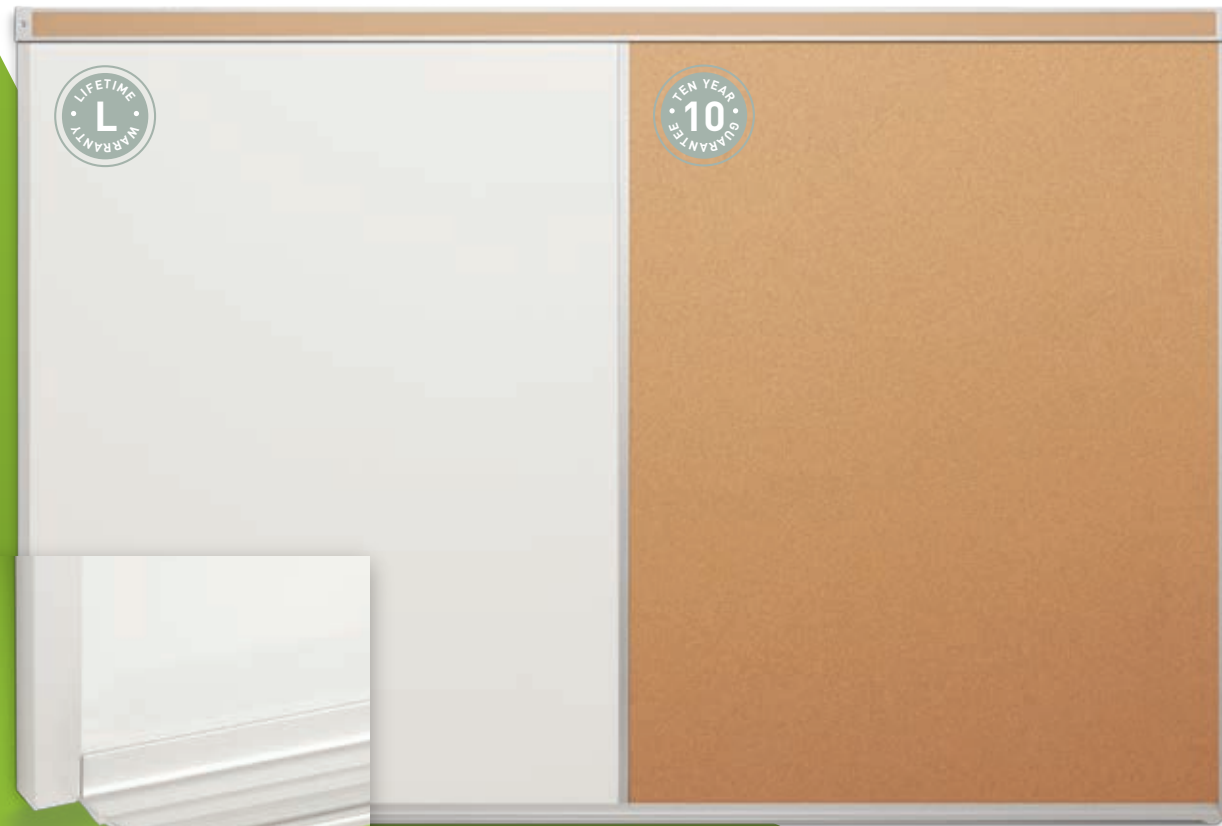
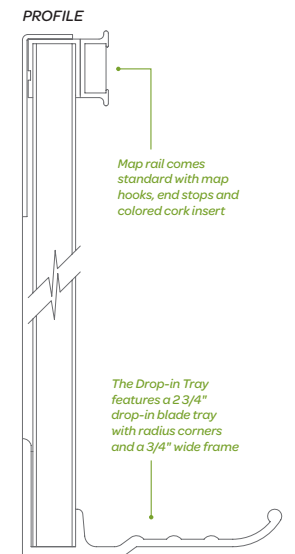
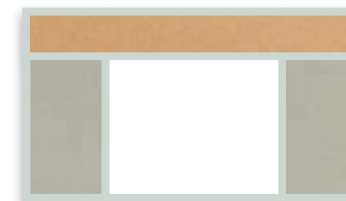

Shown: Type B



PLEASE CALL US AT 800 498 2990 FOR PRICING

PLATINUM ROLL-RITE

A double board to go. When two boards are better than one — and you need them on the move, our Platinum Roll-Rites are your ticket to write. These reversible boards rotate to provide your choice of two surfaces from our extensive variety of exceptional chalkboards, markerboards and tackboards. You can even custom imprint graphics including music staff lines, logos and graphs.

- Porcelain-on-steel, magnetic writing surfaces.
- Double-sided board rotates 360° and locks for a quick turnaround.
- Moves on rolling base designed for stability and features locking casters.
- Clear satin anodized aluminum frame with full-length accessory tray.
- 10 year guarantee on all tackboard surfaces.
- Lifetime warranty on Writanium® surfaces.
- Overall height: 72".

FIXED ROLL-RITE

MODEL SIZE (HxW)

825140500 4'x 5'
825140600 4'x 6'
825140800 4'x 8'

825240599 4'x 5'
825240699 4'x 6'
825240899 4'x 8'

8253405XX 4'x 5'
8253406XX 4'x 6'
8253408XX 4'x 8'

8251 = MARKERBOARD ON BOTH PANELS
8252 = MARKERBOARD / NATURAL CORK BULLETIN BOARD
8253 = MARKERBOARD / VINYL COVERED BULLETIN BOARD



Quality frame construction keeps writing surface steady



REVOLVING ROLL-RITE

MODEL SIZE (HxW)

825640500 4'x 5'
825640600 4'x 6'
825640800 4'x 8'

825740599 4'x 5'
825740699 4'x 6'
825740899 4'x 8'

8258405XX 4'x 5'
8258406XX 4'x 6'
8258408XX 4'x 8'

8256 = MARKERBOARD ON BOTH PANELS
8257 = MARKERBOARD / NATURAL CORK BULLETIN BOARD
8258 = MARKERBOARD / VINYL COVERED BULLETIN BOARD



Board locks easily into place with tightening knobs



Locking heavy duty casters are durable and keep board from moving when writing

PREMIUM SERIES ROLL-RITE ROOM DIVIDERS

Divide and conquer. Platinum Premium Roll-Rite Room Dividers allow you to segregate space and create privacy zones, quickly and easily. We designed our heavy-duty 16-gauged gusseted frames with four 3" swivel ball-bearing casters, two locking and two non-locking, to provide stability and ease of movement.

- Available in anodized or powder coated finish.
- Choose from multiple panel configurations.
- Surface options for panels include porcelain steel Writanium® markerboard, designer vinyl or fabric.

ROLL-RITE ROOM DIVIDERS

MODEL SIZE (HxW)

826260500 6'x 5'
826260600 6'x 6'
826260800 6'x 8'

8264605XX 6'x 5'
8264606XX 6'x 6'
8264608XX 6'x 8'

8265605XX 6'x 5'
8265606XX 6'x 6'
8265608XX 6'x 8'

8262 = MARKERBOARD ON BOTH PANELS
8264 = MARKERBOARD / VINYL COVERED BULLETIN BOARD
8265 = MARKERBOARD / FABRIC COVERED BULLETIN BOARD



WRITANIUM® MARKERBOARD



DESIGNER VINYL



FABRIC

PLATINUM ENVIROTACK™ TACKBOARDS

Earth saver. We produce our eco-friendly Platinum Envirotack™ from high quality, recycled rubber and virgin rubber material, reducing oil consumption and keeping millions of pounds of rubber waste out of landfills. Our recyclable Platinum Envirotack also meets indoor air quality and VOC emission requirements — and is free of urea-formaldehyde — making it people and planet-friendly.

- Manufactured with 1/8" thick rubber permanently bonded to 3/8" industrial grade substrate.
- Resists moisture, mold and mildew.
- Non-fading and stain-resistant.
- Available in standard size panels and extended length rolls.

DTS SERIES

MODEL	SIZE (HxW)
8380404XX	4'x 4'
8380406XX	4'x 6'
8380408XX	4'x 8'
8380410XX	4'x 10'
8380412XX	4'x 12'

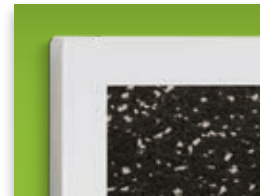

Black + White

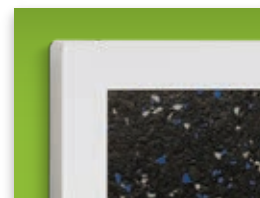

Blue + Gray

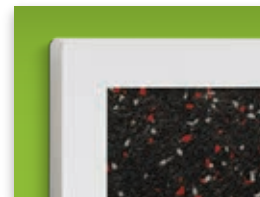

Red + Gray

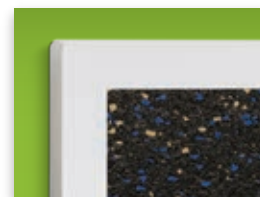

Blue + Tan

EDGES WRAPPED SYSTEM (EW)

- Frameless tackable surface without exposed edges.
- Acoustical and noise cancelling qualities.
- Economical alternative to our many trim systems.
- Versatile applications attach by adhesives or fasteners to walls, doors, cabinets — any place you can imagine.

STANDARD VINYL TACKBOARDS (ON 1/2" LIGHTWEIGHT SUBSTRATE)

MODEL	SIZE (HxW)
8120404XX	4'x 4'
8120406XX	4'x 6'
8120408XX	4'x 8'
8120410XX	4'x 10'
8120412XX	4'x 12'

PREMIUM VINYL TACKBOARDS (ON 1/8" CORK + 3/8" LIGHTWEIGHT SUBSTRATE)

MODEL	SIZE (HxW)
8121404XX	4'x 4'
8121406XX	4'x 6'
8121408XX	4'x 8'
8121410XX	4'x 10'
8121412XX	4'x 12'

STANDARD FABRIC TACKBOARDS (ON 1/2" LIGHTWEIGHT SUBSTRATE)

MODEL	SIZE (HxW)
8123404XX	4'x 4'
8123406XX	4'x 6'
8123408XX	4'x 8'
8123410XX	4'x 10'
8123412XX	4'x 12'

PREMIUM FABRIC TACKBOARDS (ON 1/8" CORK + 3/8" LIGHTWEIGHT SUBSTRATE)

MODEL	SIZE (HxW)
8124404XX	4'x 4'
8124406XX	4'x 6'
8124408XX	4'x 8'
8124410XX	4'x 10'
8124412XX	4'x 12'



Platinum boards meet the gold level indoor air quality environmental standards of the Scientific Certification Systems

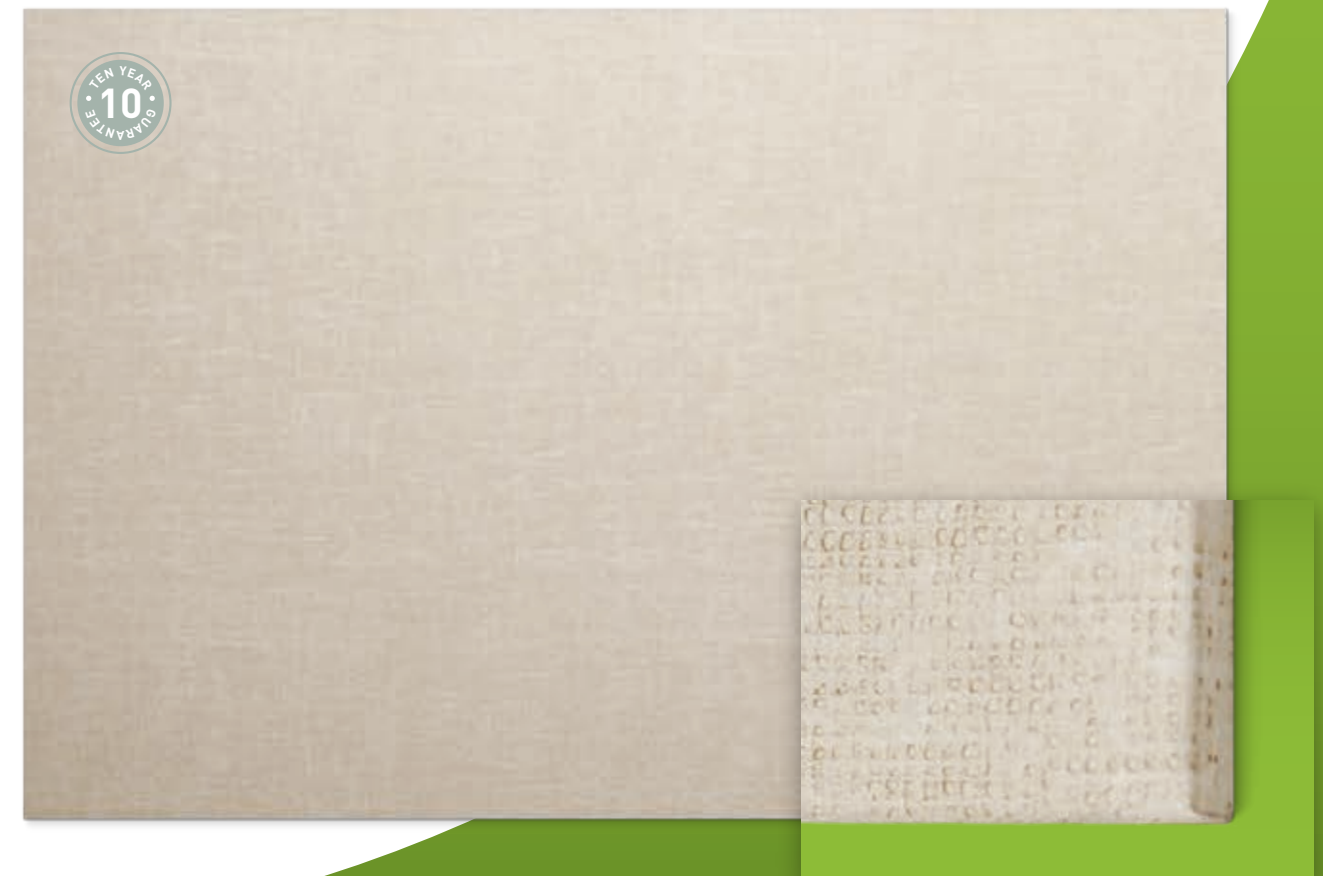

RETROFIT BOARDS

Good as new. For classrooms, businesses and other institutions with old, faded, scratched or worn markerboards or chalkboards, retrofitting with Platinum's superior advanced surface replacement technology can be the simplest, best and most economic solution. Our customized panels fit easily over old boards to update a pre-existing structure without the hassle of removing it. New retrofit non-reflective surfaces offer smooth writing and clean erasure with no glare or ghosting.

FACE-MOUNTED RETROFIT SYSTEMS

- For resurfacing markerboards or chalkboards.
- Extrusions come in standard clear satin anodized.
- Installation hardware included for fast, easy attachment over existing boards.
- Pre-drilled holes in the aluminum frame help speed installation.
- Lifetime warranty on surfaces.
- Designed to be installed over existing surfaces.
- Can be used with wood or aluminum trim finishes.

MARKERBOARD

MODEL SIZE (H)

85494WW00 48"
85495WW00 60"

WW = SUBSTITUTE FOR WIDTH IN FEET



FLOOR TO CEILING MARKERBOARDS (FCS)

Think Big. Our own big thinkers created this system for visual communication without limits. We design and manufacture oversized panels to be joined together using a concealed stabilizing spline, creating a smooth transition from panel to panel. Sizes range from 6' high by 8' wide, up to a massive 12' high by 24' wide wall system. Our team can also custom design and manufacture panels to fit any size room.

- The ideal solution for applications that require the absolute maximum amount of writing space.
- Porcelain-on-steel writing surfaces with a lifetime warranty.
- Panels come in sizes up to 4'x12' and are joined with a concealed spline butt joint.
- All extrusions are manufactured with high quality aluminum alloy to exacting specifications.
- Designed to fit any size room.
- Custom configurations are fabricated utilizing 48"W center panel(s) with balanced ends.
- Please note: Overall dimensions are increased by 7/8" (H & W) to accommodate panel installation. For example #815081200, actual dimensions are 96-7/8"H x 144-7/8"W.

EQUAL PANEL WIDTH, 8' H TRIM AND SPLINE JOINT(S) INCLUDED

MODEL	SIZE (HxW)	MODEL	SIZE (HxW)
815060800	6' x 8'	815080800	8' x 8'
815061200	6' x 12'	815081200	8' x 12'
815061600	6' x 16'	815081600	8' x 16'
815062000	6' x 20'	815082000	8' x 20'





**Always
there for you.**

Easy to reach. But never in the way. So you can pin me on the run. Write when the ideas flow. Hide me. Open me. Share me. In the classroom, boardroom, and beyond.

I'm off
the wall

Super-smart space savers. Small workspace? Make the most of it with our customizable horizontal or vertical Sliding Units for flexible visual communication solutions to fit any environment or application.

- Heavy-duty aluminum extrusions come standard in clear satin anodized.
- Also available in optional dark bronze anodized or a variety of powder coated finishes.
- Available in single, double, or triple track configuration.



Platinum boards meet
the gold level indoor air
quality environmental
standards of the Scientific
Certification Systems

WALL MOUNTED HORIZONTAL SLIDING UNITS

Slide into space. Flex your workspace muscle and maximize visual communication with a customized Wall Mounted Horizontal Sliding Unit. Double or triple the amount of usable surface with a minimum of wall space. We'll help you design a unit with your choice of writing or tackable surfaces and colors.

2 TRACKS & 2 HALF WIDTH PANELS WITH FULL BACK PANEL

MODEL	SIZE (HxW)
817840800	4' x 8'
817841000	4' x 10'
817841200	4' x 12'
817841600	4' x 16'

3 TRACKS & 3 HALF WIDTH PANELS WITH FULL BACK PANEL

MODEL	SIZE (HxW)
818240800	4' x 8'
818241000	4' x 10'
818241200	4' x 12'
818241600	4' x 16'



Shown: WHS 2 Track Horizontal Sliding Unit

PROFILE

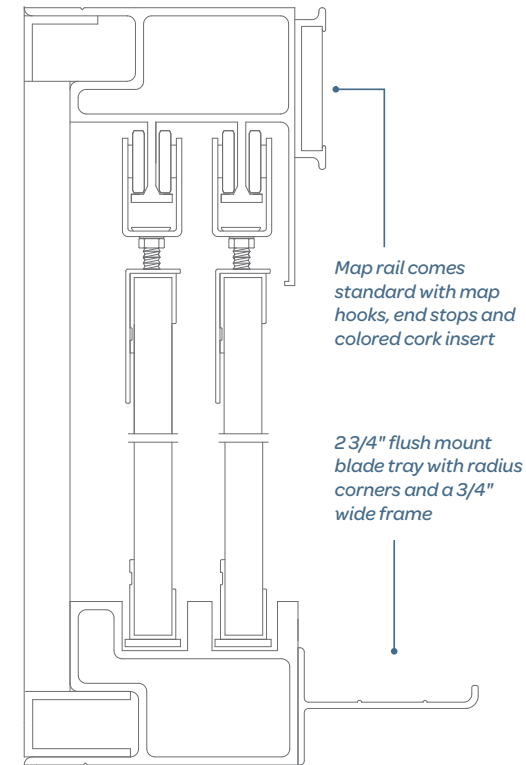

Heavy duty rollers make sliding panels effortless



Shown: WHS 3 Track Horizontal Sliding Unit

BUILT-IN HORIZONTAL SLIDING UNITS

A perfect fit. We customize our Built-in Horizontal Sliding Units without housing to use in your existing cabinetry. Choose from any of our tackable or writing surface options.

- Available in either top support (THS) or sill support (SHS) sliding panels.
- Heavy duty aluminum extrusions come standard in clear satin anodized.
- Select alternative finishes in dark bronze anodized or powder coated options.



TEACHING CENTER HORIZONTAL SLIDING UNIT (THS)

2 TRACKS & 2 HALF WIDTH PANELS

MODEL	SIZE (HxW)
815140800	4'x 8'
815141000	4'x 10'
815141200	4'x 12'
815141600	4'x 16'

3 TRACKS & 3 HALF WIDTH PANELS

MODEL	SIZE (HxW)
815540800	4'x 8'
815541000	4'x 10'
815541200	4'x 12'
815541600	4'x 16'

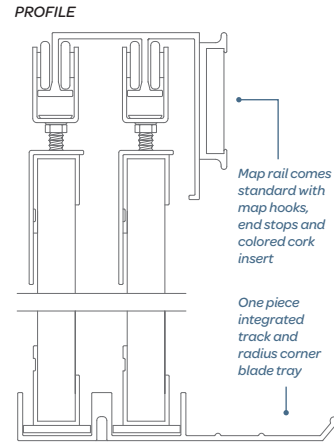

SILL SUPPORTED HORIZONTAL SLIDING UNIT (SHS)

2 TRACKS & 2 HALF WIDTH PANELS

MODEL	SIZE (HxW)
816040800	4'x 8'
816041000	4'x 10'
816041200	4'x 12'
816041600	4'x 16'

3 TRACKS & 3 HALF WIDTH PANELS

MODEL	SIZE (HxW)
816440800	4'x 8'
816441000	4'x 10'
816441200	4'x 12'
816441600	4'x 16'

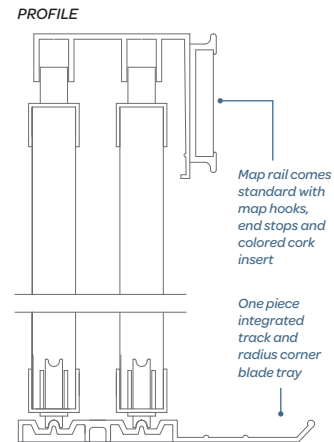

Premium rollers allow for smooth panel movement



Platinum boards meet the gold level indoor air quality environmental standards of the Scientific Certification Systems

VERTICAL SLIDING UNITS

Keep up the space. Our Vertical Sliding Units maximize visual communication and save workspace in even the tightest spots. Perfectly counter-balanced weights allow you to raise or lower one or more sliding panels in a smooth, easy motion. As with our horizontal units, you can choose from any combination of writing or tackable surfaces and colors.



Standard with finished kick panel

FLOOR MOUNTED VERTICAL SLIDING UNIT (FVS)

2 TRACKS & 2 HALF HEIGHT PANELS WITH FULL BACK PANEL AND MATCHING KICK PANEL

MODEL	SIZE (HxW)
819610800	10'x 8'
819610000	10'x 10'
819610200	10'x 12'

WALL MOUNTED VERTICAL SLIDING UNIT (WVS)

2 TRACKS & 2 HALF HEIGHT PANELS WITH FULL BACK PANEL

MODEL	SIZE (HxW)
818780800	8'x 8'
818781000	8'x 10'
818781200	8'x 12'



Heavy duty pulley system makes sliding panels effortless



Shown: Sill Supported Horizontal Sliding Unit. Furniture not included.



Everyone
deserves a
chance to stand out.

So gather your trophies.
Line the shelves. Or use me
to show the way. List. Direct.
Guide. Announce. Celebrate.
Reminisce. Present —
proudly. Open my doors to
open yours.

I'm a
show-off

Inspiration on display. We've designed these elegant enclosure systems to offer a variety of presentation options to meet your display needs — whether you're from an educational institution or a corporate setting. Choose from six sturdy designs with customizable options.



Platinum boards meet
the gold level indoor air
quality environmental
standards of the Scientific
Certification Systems

INDOOR ADVANTAGE GOLD
BUILDING MATERIALS

BULLETIN AND DIRECTORY BOARDS

Information on board. Choose from any of our tackable surfaces to create bulletin or directory boards, available in your choice of hinged or sliding door designs with our high-quality 1/4" tempered glass. Add a grooved panel to create a directory. We'll fully assemble each case for you in advance and ship it ready to hang.

- A simple, elegant display for bulletin and directory boards.
- Heavy duty aluminum extrusions come standard in clear satin anodized.
- Also available in optional dark bronze anodized or a variety of powder coated finishes.

SLIDING GLASS BULLETIN AND DIRECTORY CASE (SBS)

2 SLIDING DOORS BULLETIN W/LOCK 2 SLIDING DOORS DIRECTORY W/LOCK

MODEL	SIZE (HxWxD)	MODEL	SIZE (HxWxD)
8235404XX	4' x 4' x 3"	8236404XX	4' x 4' x 3"
8235406XX	4' x 6' x 3"	8236406XX	4' x 6' x 3"
8235408XX	4' x 8' x 3"	8236408XX	4' x 8' x 3"

Standard depth: 3"

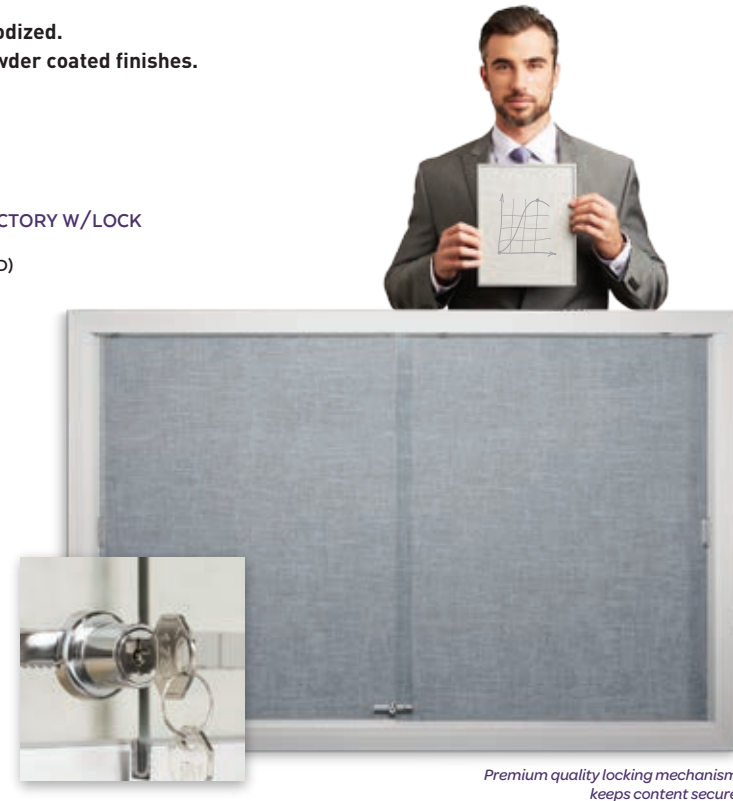

Premium quality locking mechanism keeps content secure

HINGED DOOR BULLETIN AND DIRECTORY CASE (HBS)

1 HINGED DOOR BULLETIN W/LOCK 2 HINGED DOORS BULLETIN W/LOCK 3 HINGED DOORS BULLETIN W/LOCK

MODEL	SIZE (HxWxD)	MODEL	SIZE (HxWxD)	MODEL	SIZE (HxWxD)
8221203XX	2' x 3' x 3"	8222404XX	4' x 4' x 3"	8223408XX	4' x 8' x 3"
8221303XX	3' x 3' x 3"	8222406XX	4' x 6' x 3"		
		8222408XX	4' x 8' x 3"		

4 HINGED DOORS BULLETIN W/LOCK 1 HINGED DOOR DIRECTORY W/LOCK 2 HINGED DOORS DIRECTORY W/LOCK

MODEL	SIZE (HxWxD)	MODEL	SIZE (HxWxD)	MODEL	SIZE (HxWxD)
8224408XX	4' x 8' x 3"	8225203XX	2' x 3' x 3"	8226404XX	4' x 4' x 3"
		8225303XX	3' x 3' x 3"	8226406XX	4' x 6' x 3"
				8226408XX	4' x 8' x 3"

4 HINGED DOORS DIRECTORY W/LOCK

MODEL	SIZE (HxWxD)
8228408XX	4' x 8' x 3"

Standard depth: 3"

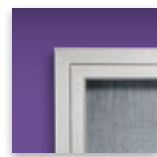

Bulletin

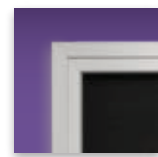

Directory



TROPHY AND DISPLAY CASES

A winning display. Show off your trophies and success stories with pride in these versatile cases, available in hinged or sliding door designs with any of our tackable surfaces as options. We use high-quality 1/4" tempered glass in construction. Adjustable shelves accommodate any accolade, regardless of size.

RECESSED DISPLAY CASE WITH HINGED GLASS DOORS (HDS)

2 HINGED DOORS W/LOCK 3 HINGED DOORS W/LOCK

MODEL	SIZE (HxWxD)	MODEL	SIZE (HxW)
8230404XX	4' x 4' x 12"	8231408XX	4' x 8' x 12"
8230406XX	4' x 6' x 12"		

Standard depth: 12"

 CUSTOM SIZES AVAILABLE. PLEASE CALL US AT 800 498 2990 FOR DETAILS.



Note: display cases are standard in Birch veneer plywood with clear finish

RECESSED DISPLAY CASE WITH SLIDING GLASS DOORS (SDS)

MODEL SIZE (HxWxD)

8239404XX	4' x 4' x 12"
8239406XX	4' x 6' x 12"
8239408XX	4' x 8' x 12"

Standard with key lock in 12" depth

 CUSTOM SIZES AVAILABLE. PLEASE CALL US AT 800 498 2990 FOR DETAILS.

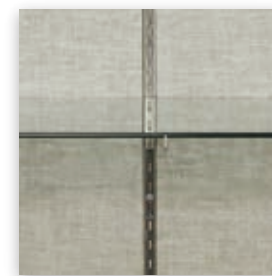

Adjustable shelves allow for display of large and small objects

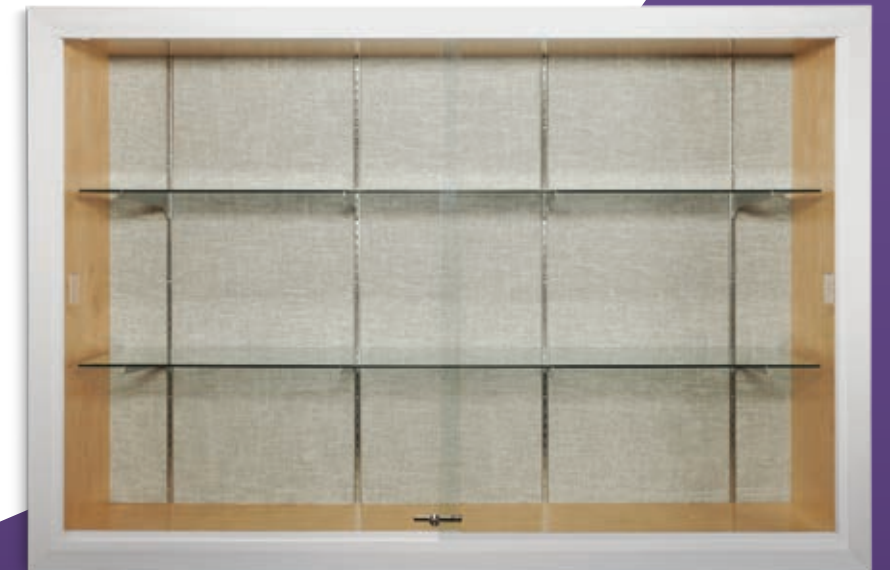

TROPHY AND DISPLAY CASE WITH SLIDING GLASS DOORS (SWS)

MODEL	SIZE (HxWxD)
8237404XX	4'x 4'x 12"
8237406XX	4'x 6'x 12"
8237408XX	4'x 8'x 12"

Standard depth: 12"

 CUSTOM SIZES AVAILABLE. PLEASE CALL US AT 800 498 2990 FOR DETAILS.

Note: display cases are standard in Birch veneer plywood with clear finish.



EXECUTIVE CONFERENCE UNITS

An open and shut case. These smart, sophisticated Executive Conference Units look impressive and make the most of your wall space. Behind the handsome closed doors, a convenient markerboard and built-in marker tray stands ready for presentations — and you can customize with a roll-down projection screen and a variety of panel surfaces and accessories. Several finish options in wood veneer and plastic laminate allow the cabinet to enhance any decor.



Shown in Cherry with clear finish

EXECUTIVE WALL CONFERENCE UNIT (ECS)

MODEL	SIZE (HxWxD)
8241404XX	4'x 4'x 5"
8241405XX	4'x 5'x 5"
8241406XX	4'x 6'x 5"



TROPHY AND DISPLAY CASE WITH HINGED GLASS DOORS (HWS)

2 HINGED DOORS W/LOCK

MODEL	SIZE (HxWxD)
8233404XX	4'x 4'x 12"
8233406XX	4'x 6'x 12"

3 HINGED DOORS W/LOCK

MODEL	SIZE (HxW)
8234408XX	4'x 8'x 12"

Standard depth: 12"

 CUSTOM SIZES AVAILABLE. PLEASE CALL US AT 800 498 2990 FOR DETAILS.

Note: display cases are standard in Birch veneer plywood with clear finish.



Premium quality locking mechanism keeps content secure

FREE STANDING TROPHY AND DISPLAY CASE WITH WOOD BASE AND UPPER CORNICE (FWS)

MODEL	SIZE (HxWxD)
8238604XX	6'x 4'x 12"
8238606XX	6'x 6'x 12"
8238608XX	6'x 8'x 12"

Note: display cases are standard in Birch veneer plywood with clear finish.



Tempered glass shelves hold up to 100 pounds



This is next level. With this up-scale, stylish surface it will prove to make any workspace functional! The GLASWRITE™ is an easy to maintain board with a polished look.



I'm the
Write Choice!

A reflection of you. GLASWRITE™ Magnetic Glassboards are available in 17 aesthetically pleasing colors. Dress your board up with a custom graphic such as; a company logo or monthly calendar. There are a variety of options for this new show-stopper!



GLASWRITE™ MAGNETIC GLASSBOARDS

A clear visionary. Elegant yet versatile our Glaswrite™ Magnetic Glassboards showcase your finest ideas coming to life. Available in a flush or an offset mount to accommodate any workspace. Glass surface will not ghost or stain and is made from tempered glass with a steel backing built to last.

- (5) Standard Sizes
- (4) Mounting Options
- Magnetic Glass
- P-100 White Standard

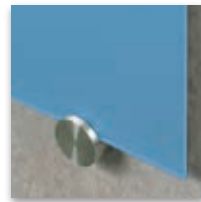

FLUSHMOUNT "PUCKS"

MODEL	SIZE (HxW)
860030400	3'x 4'
860040400	4'x 4'
860040500	4'x 5'
860040600	4'x 6'
860040800	4'x 8'

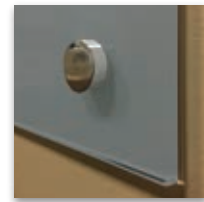

FLUSHMOUNT "CAPS"

MODEL	SIZE (HxW)
860130400	3'x 4'
860140400	4'x 4'
860140500	4'x 5'
860140600	4'x 6'
860140800	4'x 8'



WALLMOUNT "HANGER BAR"

MODEL	SIZE (HxW)
860230400	3'x 4'
860240400	4'x 4'
860240500	4'x 5'
860240600	4'x 6'
860240800	4'x 8'

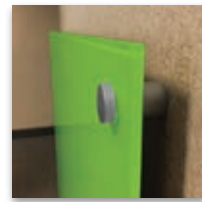

1" OFFSET MOUNT "HOLES"

MODEL	SIZE (HxW)
860330400	3'x 4'
860340400	4'x 4'
860340500	4'x 5'
860340600	4'x 6'
860340800	4'x 8'



GLASWRITE™ ACCESSORIES



GLASWRITE™ Eraser w/Logo

MODEL ACC-GLS ERASER



GLASWRITE™ Magnet, Round w/Logo

MODEL ACC-GLS MAGNET



GLASWRITE™ Accessory Kit
(INCLUDES: ERASER, PEN CUP AND 8 MAGNETS)

MODEL ACC-GLS KIT

CONTRASTING COLOR SELECTIONS

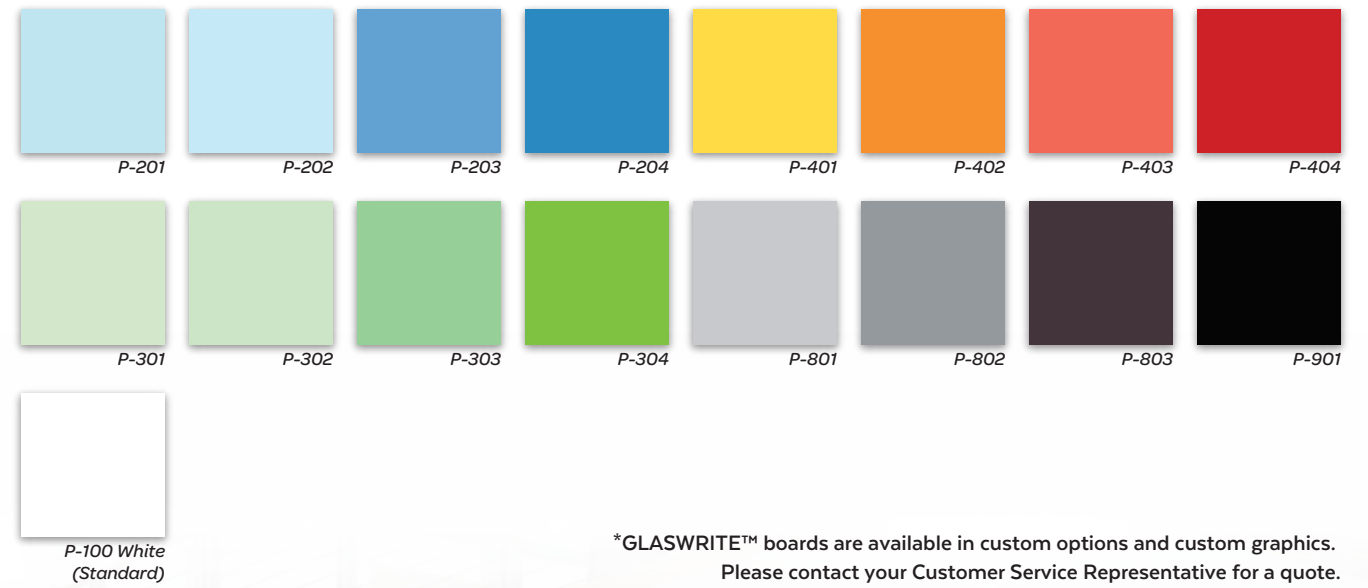

*GLASWRITE™ boards are available in custom options and custom graphics. Please contact your Customer Service Representative for a quote.





GLASWRITE MOBILEMATE™ MAGNETIC GLASSBOARDS

On the move. Add style to any classroom, office space or medical facility with Platinum's, exquisite Glaswrite MobileMate™. Available in magnetic and non-magnetic glass with nesting, perfect for easy mobility!

- Available in Magnetic & Non-Magnetic Glass
- Nesting for Easy Mobility
- (3) Standard Sizes
- P-100 Frosted White Standard



Durable Casters



Magnetic Accessory Tray



EASEL - MAGNETIC

MODEL	SIZE (HxW)
8608GWMMM	72" x 30"
8609GWMMM	72" x 36"
8610GWMMM	78" x 36"

EASEL - NON MAGNETIC

MODEL	SIZE (HxW)
8611GWMMN	72" x 30"
8612GWMMN	72" x 36"
8613GWMMN	78" x 36"



GLASWRITE MOBILEMATE™ ROOM DIVIDER WITH TACKABLE BOTTOM PANEL

VINYL BOTTOM

MODEL	SIZE (HxW)
8604GWMMXX	60" x 30"
8606GWMMXX	60" x 36"

FORBO BOTTOM

MODEL	SIZE (HxW)
8605GWMMXX	60" x 30"
8607GWMMXX	60" x 36"





Just what you need. Giant-sized for the grandest institution. Small for the tightest squeeze. Trimmed. Finished. Smart. Simple. Pin-perfect. In your favorite color. On just the right board. Exactly what you ordered.



I'm made
for you.

Simply versatile. Totally smart. Choose from eight basic designs as a foundation to create the perfect display solution to fit your needs. Our trim systems can be configured with a variety of rail, tray, board combinations and accessories to suit any application. We can also custom design and manufacture trim systems to adapt to your unique requirements.

We make all aluminum extrusions to our exacting specifications with high quality 6063-T5 aluminum alloy. Extrusions come standard in clear satin anodized, with optional dark bronze anodized and your choice of powder coated finishes.

Enhance your trim system with our matching map rails, trays and writing accessories. And choose from our extensive offering of surface styles and color options to create the perfect visual display system for your environment.

DRY ERASE MARKERS

On your mark. Go. Write smoothly in a bold array of distinctive colors. Long-lasting firm tips help make your point. Designed for fast, easy erasure with no residue. A perfect match for our Writanium® surfaces.

MODEL	DESCRIPTION
851900000	1 Black, Blue, Green, and Red Marker



MAGNETIC TRAYS

Go with the flow. These attractive, portable magnetized trays hold markers and chalk to let inspiration take you across the board. Trays can be easily and quickly transferred for a secure attachment as you write. A perfect accessory for our Floor to Ceiling Markerboards.

MODEL	DESCRIPTION
852600000	12" Satin
852700000	12" White
852800000	18" Satin
852900000	18" White



MAP RAIL ACCESSORIES

The perfect attachments. Adapt your trim system to your special needs with 1" or 2" matching map rails lined with durable cork inserts. Each accessory, made of extruded aluminum, offers a snug fit to Platinum map rails and a seamless look with each visual system. Customize with flag holders or clips to display maps or other visual tools; end stops create a finished look. Roller brackets secure rolled maps and screens.

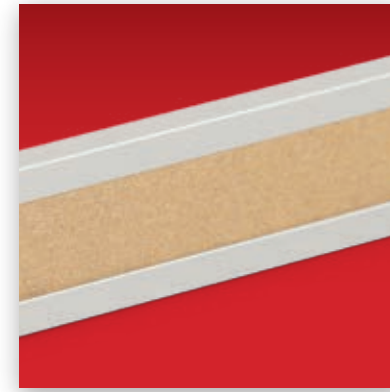

MAP AND DISPLAY RAILS WITH COLORED CORK INSERTS

MODEL	SIZE
85000LF11	1"
85020LF11	2"
850600811	1" (6 8' PIECES)*
850800811	2" (6 8' PIECES)*

*Pre packaged



END STOPS

MODEL	SIZE
851000000	1"
851100000	2"



MAP HOOKS

MODEL	SIZE
851300000	1"
851400000	2"



ROLLER BRACKETS

MODEL	SIZE
851700000	1"
851800000	2"



FLAG HOLDER

MODEL	SIZE
851500000	1"
851600000	2"

UNFRAMED MATERIAL

DIY like the pros. Platinum offers an extensive variety of board surfaces as unframed flat stock for your easy installation. Choose from our sleek Writanium® markerboard and chalkboard porcelain-on-steel surfaces; natural and colored cork; or vinyl and fabric-covered panels. Make your old boards brand new in a snap.

MARKERBOARD & CHALKBOARD

- Six different magnetic porcelain-on-steel surface bonded to 1/8", 1/4" or 1/2" durable substrate.
- Standard at 48" high.
- Smooth writing, easy erasure and superior color contrast.
- Durable, nonporous, scratch-resistant surface withstands heavy use and harsh cleaning.
- Flame resistant surface - 100% noncombustible.
- Lifetime warranty on surfaces.

MODEL	DESCRIPTION
85454WWXX	1/8" Markerboard
85464WWXX	1/8" Chalkboard
85474WWXX	1/4" Markerboard
85484WWXX	1/4" Chalkboard
85514WWXX	1/2" Markerboard
85524WWXX	1/2" Chalkboard

COLORED & NATURAL CORKBOARD

- Natural cork panels offered in two surfaces: 1/8" natural cork bonded to a 3/8" lightweight substrate and 1/4" natural cork over a 1/4" durable substrate.
- Standard at 48" high.
- Colored cork flat stock available in 1/4" moisture-resistant material bonded to a 1/4" durable substrate.
- 10 year guarantee.

MODEL	DESCRIPTION
85534WW99	Premium Natural Cork (1/8" NATURAL CORK ON 3/8" LIGHTWEIGHT SUBSTRATE)
85544WW99	Deluxe Natural Cork (1/4" NATURAL CORK ON 1/4" DURABLE SUBSTRATE)
85554WWXX	Colored Cork (1/4" CORK ON 1/4" DURABLE SUBSTRATE)

VINYL & FABRIC-COVERED PANELS

- Vinyl and fabric covered panels come in three substrates: Laminated to 1/2" lightweight substrate, 1/8" layer of natural cork bonded to 3/8" lightweight substrate or over a 1/4" natural cork bonded to 1/4" durable substrate.
- Standard at 48" high.
- Easy to clean; fade and soil resistant.
- In a variety of décor-friendly colors.
- Treated to resist odor and stain-causing microbes.
- 10 year guarantee.

MODEL	DESCRIPTION
85564WWXX	Vinyl (ON 1/2" LIGHTWEIGHT SUBSTRATE)
85574WWXX	Fabric (ON 1/2" LIGHTWEIGHT SUBSTRATE)
85584WWXX	Vinyl (ON 1/8" CORK + 3/8" LIGHTWEIGHT SUBSTRATE)
85594WWXX	Fabric (ON 1/8" CORK + 3/8" LIGHTWEIGHT SUBSTRATE)
85604WWXX	Vinyl (1/4" CORK ON 1/4" DURABLE SUBSTRATE)
85614WWXX	Fabric (1/4" CORK ON 1/4" DURABLE SUBSTRATE)

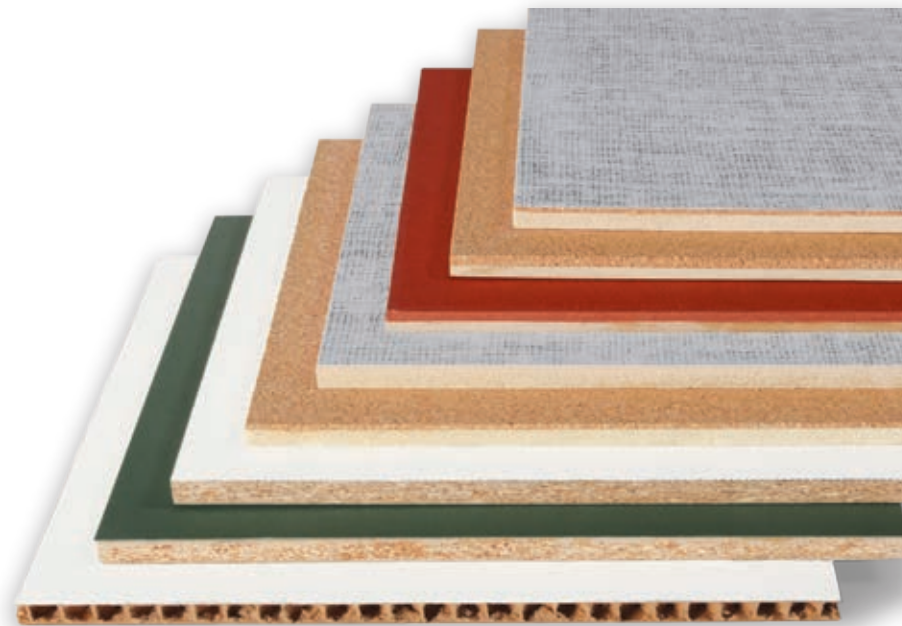

Platinum flat stock is available in an extensive variety of surfaces for easy upgrade of existing boards

ROLL STOCK

On a roll. Choose colored cork or burlap-patterned vinyl as superior replacement covers for weathered, decaying boards. Versatile roll stock natural cork also makes an excellent extended surface for tacking and display, as well as sound and shock absorption, or recovering old tackboards. Durable and resilient, these cork and vinyl rolls unfurl for all your custom applications. Installation kit included; some hardware and adhesive optional.

COLORED CORK ROLL STOCK

- 1/4" thick, burlap-backed colored cork stock standard at 48" high.
- Made from linseed oil, granulated cork, rosin binders and dry pigments for color throughout.
- Self-healing cork surfaces resist drying, cracking and peeling.
- Naturally self-sanitizing to inhibit contaminants.
- Fade-free, soil-resistant and Class A fire-rated.
- 10 year guarantee.

MODEL	DESCRIPTION
85644WWXX	Colored Cork 1/4"

NATURAL CORK ROLL STOCK

- All natural ingredients in 1/4" and 1/8" thick, 48" high, natural cork stock.
- Self-healing cork surfaces resist drying, cracking and peeling.
- Naturally self-sanitizing to inhibit contaminants.
- Fade-free, soil-resistant and Class A fire-rated.
- Plain cork rolls available in Natural only.
- 10 year guarantee.

MODEL	DESCRIPTION
85624WW99	Natural Cork 1/8"
85634WW99	Natural Cork 1/4"

ENVIROTACK™ ROLL STOCK

- Resists moisture, mold and mildew.
- Non-fading and stain-resistant.

MODEL	DESCRIPTION
85674WWXX	EnviroTack™ 1/16"
85664WWXX	EnviroTack™ 1/8"
85654WWXX	EnviroTack™ 1/4"

SURFACE COLORS

Full spectrum favorites. Choose from a wide variety of colors for your board surfaces. Writanium® markerboard and chalkboard colored surfaces offer high contrast and sharper definition. Our colored cork, vinyl and fabric tackboards come in a broad range of surface hues designed to complement contemporary or classic interior colors.

Writanium® Markerboards

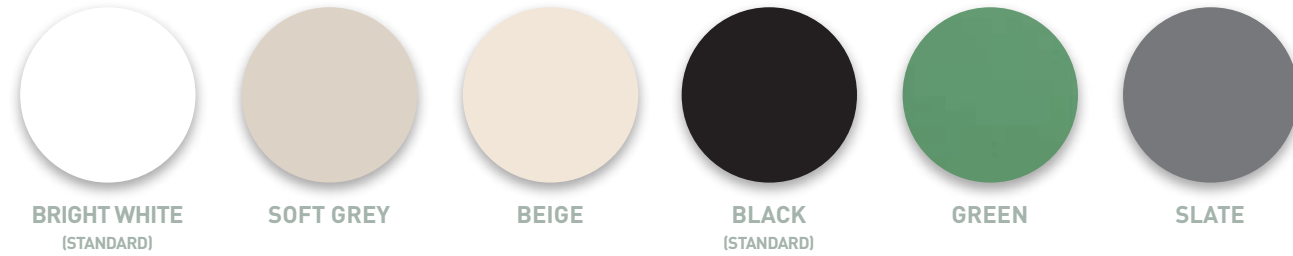

Writanium® Chalkboards

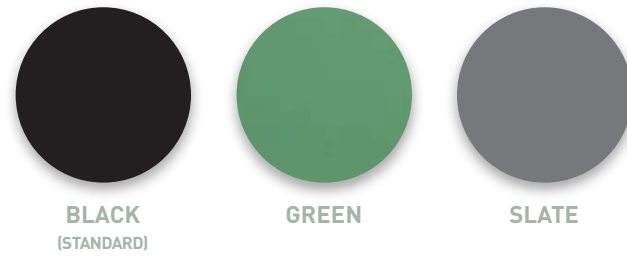

Natural Cork



EnviroTack™

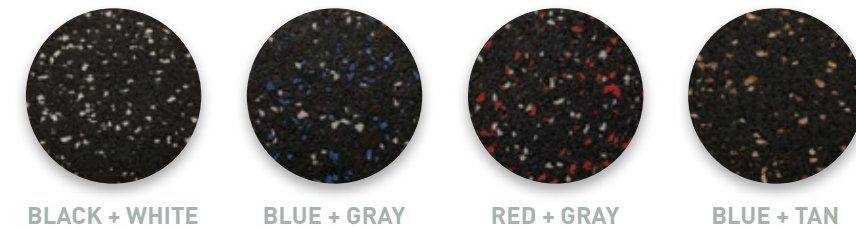

Colored Cork



Vinyl

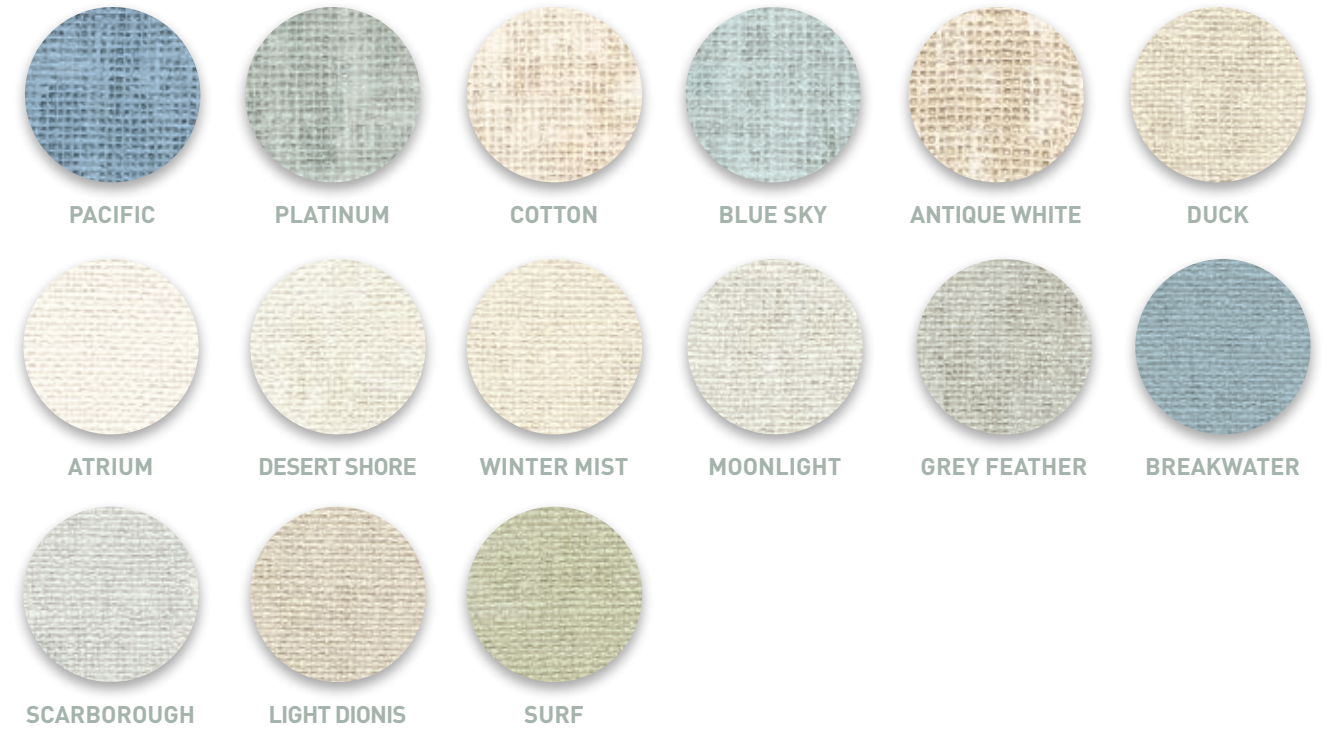

Fabric

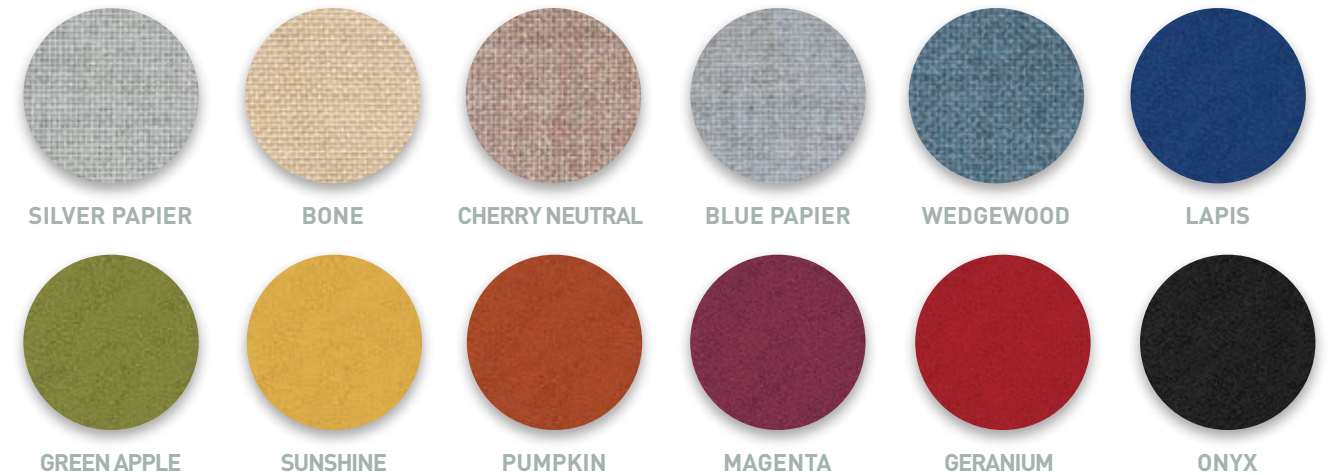

Note: Color swatches are printed approximations and actual color may vary. If exact match is required, please contact us to request a sample.

TRIM SYSTEM COLORS

Heavy-duty aluminum extrusions come standard in clear satin anodized. Also available in optional dark bronze anodized or a variety of powder coated finishes.



Also available in optional dark bronze, black or a variety of powder coated finishes. Optional finishes are specially priced. Please contact your customer service specialist for current cost and availability.

VENEER & FINISH COLORS

Choose from 5 beautiful stock wood veneer and laminate color options for use with our FWS and ECS units. Virtually any laminate can be used to build PVS cases and cabinets. Please call for pricing and availability.



Standard finish is Birch with clear coat. Walnut, Mahogany, Oak and Cherry are specially priced. Please contact your customer service specialist for current cost and availability.

Note: Color swatches are printed approximations and actual color may vary. If exact match is required, please contact us to request a sample.

TERMS & CONDITIONS

Platinum Visual Systems reserves the right to alter, change, modify, expand, or discontinue any of the policies set forth below. Platinum Visual Systems further reserves the right to alter, change, modify, or discontinue its programs, policies, or relationship with any customer who violates Platinum Visual Systems' stated terms and conditions. The terms and conditions below are not intended to be a full, comprehensive, and complete detail of each subject.

Orders & Order Acknowledgements

All orders must be submitted in writing by US mail, Fax, or E-mail. Verbal orders are not acceptable. Your order information must be complete so we can enter your order promptly and schedule it for manufacturing and shipment. It is the Buyer's sole responsibility to check orders and their corresponding acknowledgments for accuracy. It is also the Buyer's responsibility to notify Platinum Visual Systems of any acknowledgment discrepancies within 48 hours. Orders for custom designs, custom and non-stocked material will be acknowledged within 48 hours of receipt of the completed order. A minimum order of \$200 is required.

Lead Times

Lead times are established at time of order entry. It is our goal to meet all requested ship dates. Unforeseen product issues may arise which may cause a delay. If this should occur notification will be given as soon as possible.

New Customers

All new customers will need to complete a credit application, unless prepayment is preferred. Upon credit approval, orders will be manufactured and invoiced based upon the information on the acknowledgment.

Returned Merchandise

Our goal of 100% customer satisfaction allows the return of standard products with a 40% restocking charge. Return freight charges must be prepaid. Return merchandise must be unused and in resalable condition for credit to be issued. All returned merchandise must have an RA number issued by customer service prior to merchandise being returned. Orders with custom non-stock material are non-refundable.

Freight, Damages or Shortages

Every effort will be made to ship in accordance with customer requested freight carriers. Platinum Visual Systems is not responsible for damage in shipment when product is shipped on a third party or collect basis. In the event of visible freight damage, note damage on the freight bill and notify the carrier at once for inspection. Note: carriers require reporting damage within 15 days of delivery.

Failure to report visible damage or loss is the consignee's responsibility. Taking photographs of any damage product, shipping carton, container, packaging, etc. is highly recommended. You have the right to refuse the delivery of any shipment showing visible damage, or to note "possibility of concealed damage" if the packaging is questionable. If the possibility exists for concealed damage opening and inspection the merchandise should be completed at the first available opportunity. Upon inspecting and verifying the order any shortages discovered should be reported to customer service immediately.

Color Variations

Color variations may occur between actual finishes and what is shown in catalog reproduction. Actual finish samples are available upon request. Platinum Visual Systems cannot be held responsible for reasonable variances.

Payment Terms

For credit approved customers, all merchandise will be invoiced when shipped; FOB Corona, CA 92879, Standard terms are net 30 days. Buyer agrees that Platinum Visual Systems shall have the right to assess interest charges of 1.5% per month on invoices not paid and received by Platinum Visual Systems within terms.

Change Orders & Cancellations

All change orders must be in writing. Additional charges may apply. All orders are considered firm and cannot be cancelled except by written consent from Platinum Visual Systems. Should Platinum Visual Systems consent to cancelling an order a cancellation fee of no more than 25% will apply. Orders with custom or non-stocked material are subject to a 100% cancellation fee.

WARRANTY

For the lifetime of the original installation, Platinum Visual Systems warrants that the porcelain-on-steel finish, under normal conditions of use, shall not exhibit excessive fading of color, crazing, cracking or flaking. Platinum Visual Systems warrants the following products for ten years from the date of sale: Colored Cork Tackboards; Vinyl Tackboards; Fabric Tackboards; Natural Cork Tackboards; and Cork Roll Stock. Our obligation under these warranties is limited to supplying, free of charge, new products for the defective goods, or at our option, refunding the purchase price thereof, with due allowance made for the service rendered by such products. All products are sold and warranted only pursuant to our published terms and conditions of sale. We are not responsible to the user for any consequential, incidental or special damage resulting from improper use or installation. Platinum Visual Systems reserves the right to modify or discontinue any of our warranted products. Warranty does not cover the cost, removal or reinstallation.





PLATINUM

LET'S CREATE TOGETHER.™

1451 E. 6th Street, Corona, CA 92879
800 498 2990 | 951 817 2200 | FAX 951 817 9900
www.pvsusa.com | info@pvsusa.com



PROUDLY
MADE IN
THE USA

PVS2001 ©2020 Platinum Visual Systems



MIX
Paper from
responsible sources

FSC® C002429