

KC
drawn by
KP
checked by
JULY 2023
date
revisions

MOORE PUBLIC SCHOOLS
BOARD OF EDUCATION
MOORE, OKLAHOMA



CLASSROOM ADDITION
HIGHLAND WEST
JUNIOR HIGH SCHOOL

sheet no:

P110

OWNERSHIP USE OF DOCUMENTS:
AGP EXPRESSLY RESERVES ITS
COPYRIGHT AND OTHER PROPERTY
RIGHTS OF ALL PLANS AND DRAWINGS
DESIGNED AND/OR PRODUCED. PLANS
AND DRAWINGS ARE NOT TO BE
REPRODUCED IN ANY FORM OR MANNER
WITHOUT THE EXPRESSED WRITTEN
CONSENT OF AGP.

GENERAL NOTES

- COORDINATE WORK WITH ALL OTHER TRADES ON SITE.
- PROVIDE WATER HAMMER ARRESTORS (HA) ON WATER LINES TO FLUSH VALVES, SENSOR FAUCETS AND QUICK CLOSING VALVES. LOCATE UNITS IN ACCESSIBLE LOCATIONS.
- SINK AND LAVATORY WATER SUPPLY STUB OUTS SHALL BE COPPER PIPE WITH SUPPORT BRACKET FASTENED IN WALL CAVITY.
- FIRE SEAL ALL PENETRATIONS THRU RATED STRUCTURES TO MAINTAIN FIRE RATING.
- REFER TO PLUMBING FIXTURE SCHEDULE ON SHEET P601 FOR FIXTURE ROUGH-IN PIPE SIZES.
- PROVIDE ACCESS PANELS FOR ALL VALVES/DEVICES ABOVE HARD CEILINGS AND BEHIND WALLS.
- ALL GAS PIPE SHALL COMPLY WITH IFGC. BRANCH LINES SHALL TAP OFF TOP OF GAS MAINS AND INSTALL SHUT-OFF VALVE ON BRANCH LINE.
- TRAP PRIMER LINES SHALL BE COPPER TYPE "K" OR PEX-g TUBING WITH CONTINUOUS SLOPE TOWARDS DRAIN CONNECTION.
- COORDINATE HEIGHT OF EXTERIOR FREEZELESS WALL HYDRANT (FWH) WITH GC AND/OR ARCHITECT. SEAL FIXTURE FLANGE WATERTIGHT.
- INSULATE STORM DRAIN AND SLOPE DOWN AT 1/8" PER FOOT.

KEYED NOTES

- INSTALL THERMOSTATIC MIXING VALVE (TMV-1) BELOW SINK. CLASSROOM SINKS SEE DETAIL 8/P501. STORAGE ROOM SINKS SEE DETAIL 5/P501.
- PROVIDE 1/2" CW WITH STRAINER TO TRAP PRIMER (TP-1) IN ACCESSIBLE LOCATION IN FURNACE CLOSET. ROUTE 1/2" LINE FROM UNIT TO HUB DRAIN. COORDINATE POWER WITH EC. SEE DETAIL 1/P501.
- PROVIDE 1/2" CW WITH STRAINER TO TRAP PRIMER (TP-1) IN ACCESSIBLE LOCATION ON WALL IN PLUMBING CHASE. ROUTE (3) 1/2" LINES FROM DISTRIBUTION UNIT TO FLOOR DRAINS IN THIS AREA. SEE DETAIL 1/P501.
- COORDINATE CHASE SIZE WITH GC FOR STORM DRAIN PIPE. INSTALL FLOOR PIPE SUPPORT FOR ELBOW. INSTALL BOTTOM OF DOWNSPOUT NOZZLE AT 8" ABOVE GRADE. COORDINATE HEIGHT WITH GC.
- ROUTE 1" NATURAL GAS (LOW PRESSURE) LINE TO FURNACE. PROVIDE BALL VALVE, DRIP LEG, AND FINAL UNIT CONNECTION. COORDINATE CONNECTION WITH MC. SEE DETAIL 7/P501.
- ROUTE 3" NATURAL GAS LINE UP THRU ROOF.
- PROVIDE 3/4" CW WITH BALL VALVE TO CONNECTION FOR ROOF HYDRANT (FRH).

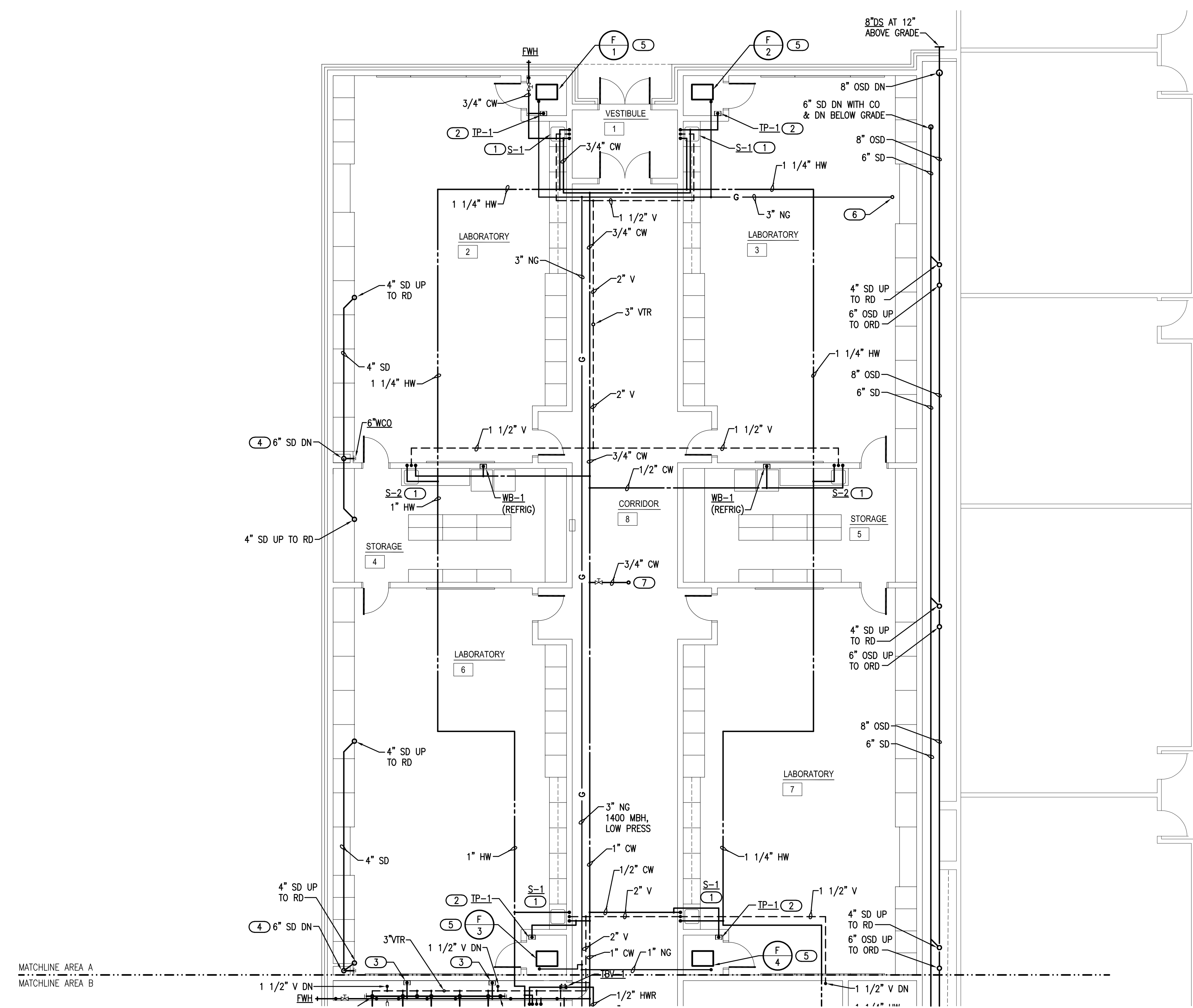

1 PLUMBING PLAN - ABOVE - AREA A
SCALE: 1/8" = 1'-0"

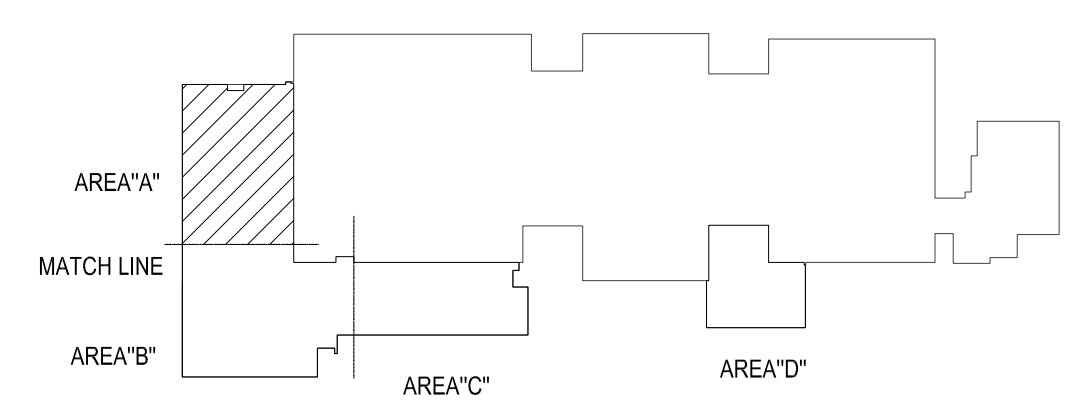

KEY PLAN

Salas O'Brien
2600 Van Buren St., Suite 2635
Norman, OK 73072
Sales O'Brien Registration: CA# 7058
Expiration Date: 8/30/2025
Salas O'Brien Project Number: 2023-02792-00